

RS & RT

REDUCTORES DE TORNILLO SIN FIN

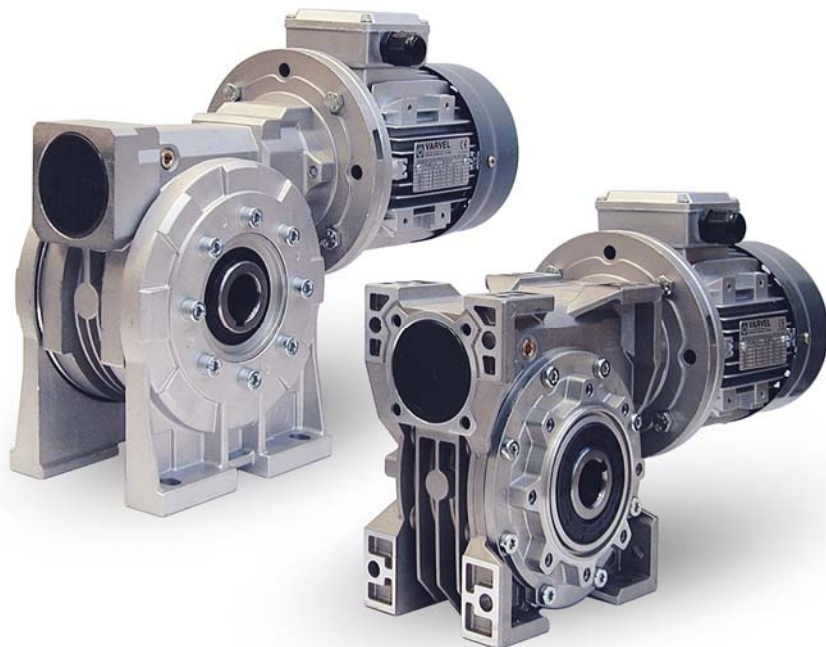

Reductores Serie RS y RT

Descripción del producto

Carcasa multiuso

Aluminio colado bajo presión y Fundición gris
Modular por todos los montajes

Vis-sin-fín

Perfil ZI,
cementado y templado.
Acero legado.

Corona

Fusión en bronce
sobre moyú de fundición.

Rodamientos

de bolas o rodillos.
Rodillos conicos
para servicio pesado.



Entrada

Motores IEC y NEMA
con acoplamiento universal
o agujero tradicional

Retenes

NBR como standard,
Viton y Silicona
sobre demanda.

Salida

Eje hueco como standard
y simple o doble
sobre demanda.

Piezas Modulares

Pre-reductor de engranajes, Brida de salida,
Brazo de reacción y Limitador de par.

Tornillo sin fin RS y RT

Los reductores de tornillo sin fin series RS y RT diseñados específicamente para fijación universal, son construidos con carcasa y tapas de aluminio hasta el tamaño 85 y de fundición desde el tamaño 110, Los pares indicados en las tablas de selección son pares de salida del tamaño considerado y las potencias de entrada se refieren a una velocidad de entrada de 1440 rpm.

Los retenes de entrada de Viton o Silicona, montados sobre demanda, hacen posible sin problemas el accionamiento con motores de 2 polos o motores C.C. a 3000 rpm, o a las bajas temperaturas.

Los reductores se entregan ya llenados con aceite sintético de larga duración (sin tapones) en las cantidades indicadas validas para cualquier posición de funcionamiento.

Los valores de las tablas de selección se entienden para una factor de servicio FS1.0 correspondiente a un funcionamiento de 8-10 horas al día, con carga uniforme, menos de 6 arranques hora y una temperatura ambiente entre 15 y 35 °C.

Tornillo sin fin y engranajes RA y TA

Los reductores de la serie RA y TA, compuestos por un reductor independiente de un tren de engranajes montado sobre un reductor standard del tipo FRS o FRT, permiten un par mayor de salida y un rendimiento mas elevado que el obtenido por un reductor tipo RS o RT de una reducción equivalente.

Reductores Serie RS y RT

Descripción del producto

Reductores de doble tornillo sin fín RS/RS y RT/RT

La serie RS/RS y RT/RT está compuesta por 2 reductores de la serie RS o RT y ofrecen una amplia gama de elevadas reducciones como complemento a la serie RA y TA para poder obtener velocidades de salida más lentas.

Ejes de AS y AD

Todos los reductores se construyen normalmente con eje de salida hueco, y sobre demanda, se puede suministrar el eje de salida lento, simple AS o doble AD, de acero C43 y una protección de seguridad ASC para el extremo no utilizado del eje AS.

Brazo de reacción BR/BRV y BT/BTV

Los reductores standard se suministran normalmente con tapas en ambos lados para la fijación del brazo de reacción cuando el reductor va montado en ejecución pendular.

El brazo de reacción BR o BT versión simple y BRV o BTV con casquillo antivibratorio de Vulkollan es de chapa gruesa zincado blanco.

Directiva ATEX

Los reductores serie VARVEL-ATEX, suministrados sobre demanda, están diseñados y fabricados de acuerdo con la Directiva 94/9/CE "ATEX" y por ello, están cualificados para su instalación en atmósferas potencialmente explosivas en las Zonas del Grupo II,

- Categoría 2 (o 3)
- Riesgo de explosión con presencia de gas (Zona 1 o 2),
- Riesgo de explosión con presencia de polvo combustible (Zona 21 o 22).

Las unidades VARVEL-ATEX se identifican por el marcaje:

 II 2 GD ck IP66 T_{max}=135 °C

Reductores Serie RS y RT

Descripción del producto

	ESPECIFICACIONES GENERALES
Gama	9 tamaños RS + 9 tamaños RT 55 relaciones de reducción 3020 Nm par máx. de salida
Dimensionado	Según BS721 Vida media 15000 horas con factor de servicio SF1
Carcasa, Tapas	Aluminio inyectado AlSi12Cu2Fe hasta el tamaño 85 Fundición G25 desde 110
Partes dentadas	Vises de acero 20MnCr5 cmt/tmp con perfil ZK rectificado. Coronas de bronce CUsn12 sobre moyú de fundición
Ejes & Chavetas	Acero C43 Ejes h6, agujeros E8 Chavetas según DIN6885 B1
Rodamientos	De bolas o rodillos según tamaño y especificaciones técnicas
Retenes	Tipo NB – nitrilo-butadieno con segundo labio anti-polvo según DIN 3760
Lubrificante	Aceite sintético de larga duración tipo ISO VG 320
Pintado al horno	RS/RT>85: pintura de polvo epoxy, color std, RAL7012 RS/RT 28-÷85: aluminio natural.

Reductores Serie RS y RT

Designación

DESIGNACIÓN REDUCTOR

F SR [./] 40 B3 28 IEC71 B14 (OPS, OPP)

OPS = Opciones standard pág. 34-42
 OPP = Opciones standard página

B5, B14 = Forma constructiva motor

Tamaño motor

Relación de reducción

Posiciones de montaje

Tamaño reductor

RS (28, 40, 50, 60, 70, 85, 110, 130, 150) - RT (28, 40, 50, 60, 70, 85, 110)

Tamaño pre-reductor RA (63/, 71/, 80/, 100/)

Tamaño 1er reductor RS - RT (28/, 40/, 50/, 60/, 70/)

Tipo reductor

- M = Moto-reductor
- F = Brida entrada IEC
- S = Sin brida entrada
- ... = Nada - Eje de entrada libre

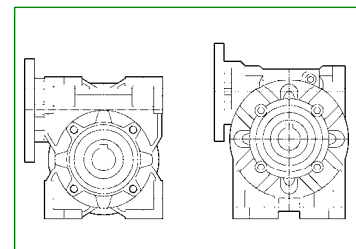

DESIGNACIÓN MOTOR

MT 0,37 kW 71b4 B14 230/400/50 IP55 F X1

Posición caja de bornes

Cl. F (std) = Clase de aislamiento

IP55 (std) = Grado de protección

Tensión / Frecuencia

B5 o B14 = Forma constructiva

Tamaño motor IEC y Número de polos

Potencia motor

- MT = Motor trifásico
- MM = Motor monofásico
- MA = Motor autofrenante

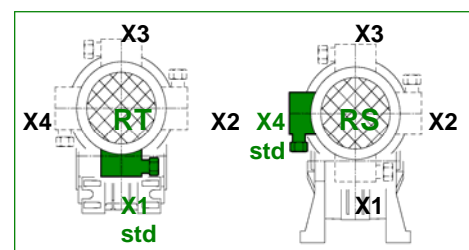

OPCIONES OPP

El lado standard de fijación, salvo indica-ción contraria, es a la derecha visto desde la entrada.

- ACØ - Eje hueco no standard ø... mm
- CS - Rodamientos salida no std
- FL - Brida salida FL adicional

- GRM - Juego reducido montaje
- LNS - Lubricación no std
- VB - Vis prolongado



Reductores Serie RS y RT

RS

Posiciones de montaje

RS , RA , RS/RS

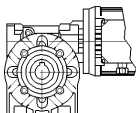
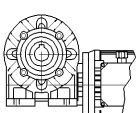
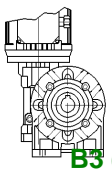
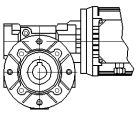
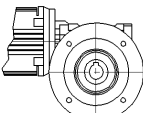
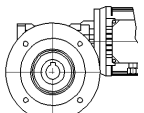
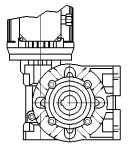
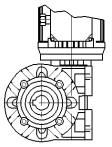
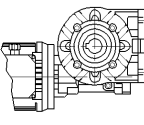
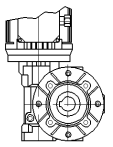
Salida

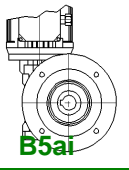
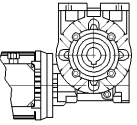
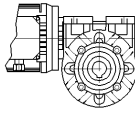
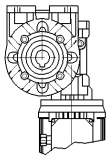
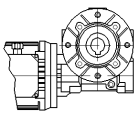
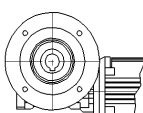
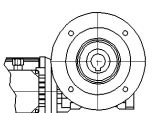
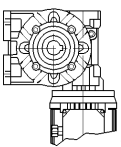
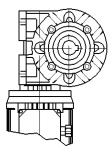
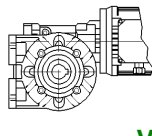
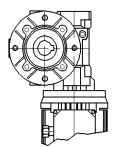
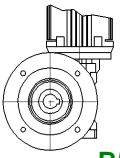
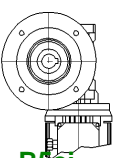
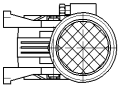
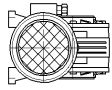
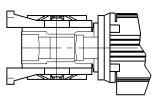
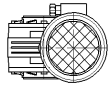
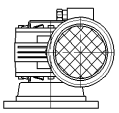
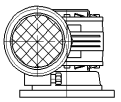
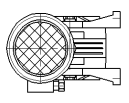
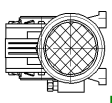
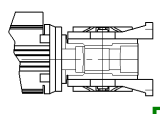
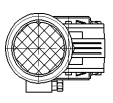
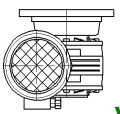
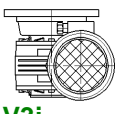
S - SA	I - IA	D - DA	PC - PC	FL - FA - FB - PA - PB	
 B3 (std)	 B3 (std)	 B3 (std)	 B5 (std)	 B5 (std)	 B5i
 V5	 V5	 V5	 B5	 B5a	 B5ai
 B8	 B8	 B8	 B5	 B5b	 B5bi
 V6	 V6	 V6	 B5	 B5c	 B5ci
 B6	 B6	 B6	 V1	 V1	 V1i
 B7	 B7	 B7	 V3	 V3	 V3i

RA

Entrada

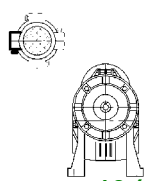
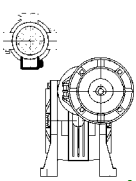
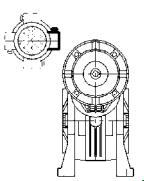
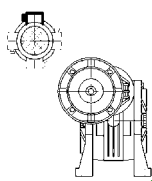
 10 (std)	 11	 12	 13		
--	--	--	--	--	--



RS

Reductores Serie RS y RT

Posiciones de montaje

RS / RS

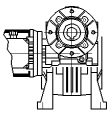
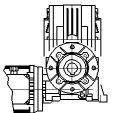
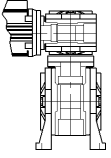
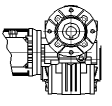
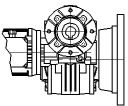
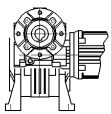
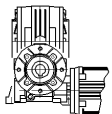
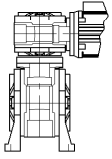
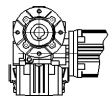
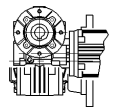
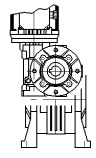
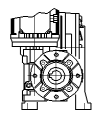
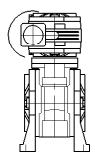
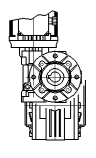
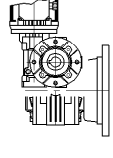
Salida

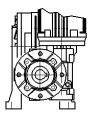
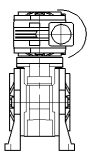
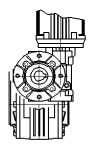
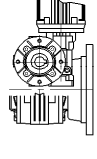
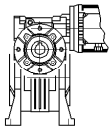
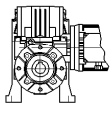
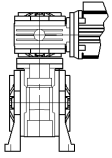
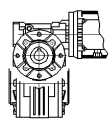
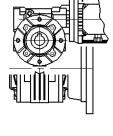
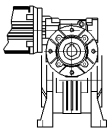
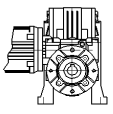
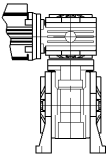
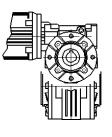
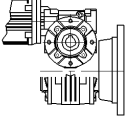
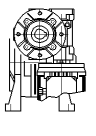
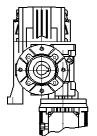
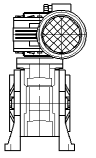
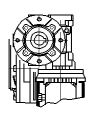
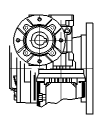
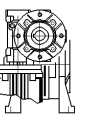
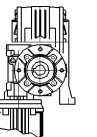
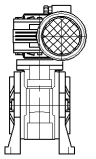
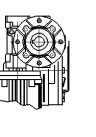
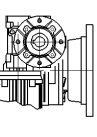
	S - SA	I - IA	D - DA	PC - PA - PB	FL - FA - FB
11					
12					
13					
14					
15					
16					
17					
18					

Reductores Serie RS y RT

RT

Posiciones de montaje

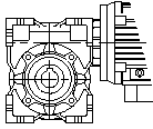
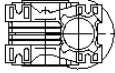
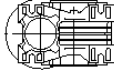
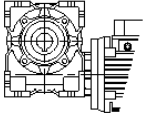
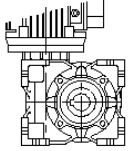
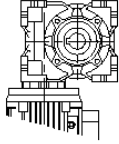
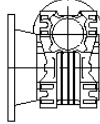
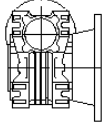
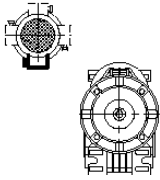
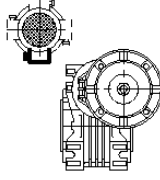
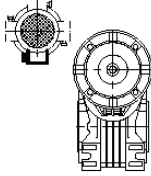
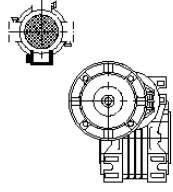
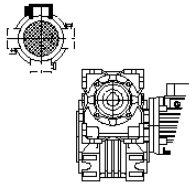
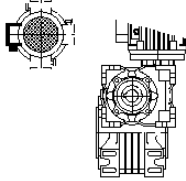
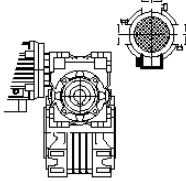
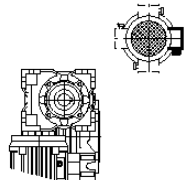
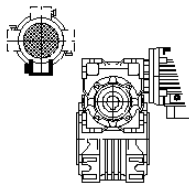
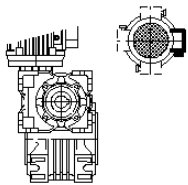
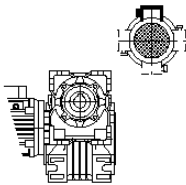
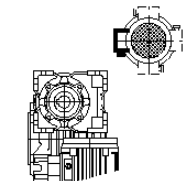
RT TA RT/RT Salida	 <p>B3 (std)</p>	 <p>B6</p>	 <p>B7</p>	 <p>B8</p>
	 <p>V5</p>	 <p>V6</p>	 <p>F (std)</p>	 <p>Fi</p>
TA Entrada	 <p>10 (std)</p>	 <p>11</p>	 <p>12</p>	 <p>13</p>
RT/RT Entrada	 <p>20 (std)</p>	 <p>21</p>	 <p>22</p>	 <p>23</p>
	 <p>24</p>	 <p>25</p>	 <p>26</p>	 <p>27</p>

Reductores Serie RS y RT

Factores de servicio - Pesos - Lubrificantes

FACTORES DE SERVICIO

$$FS = F_1 \times F_2$$

Carga F_1	uniforme	variable	con choques	Arran- ques F_2	arran- ques/ hora
3 - 4 h	0.8	1.0	1.5	6	1.0
8 - 10 h	1.0	1.2	1.8	60	1.2
10 - 24 h	1.4	1.6	2.0	120	1.4

PESOS Y LUBRIFICANTES (litros)

RS - RT	kg	l	RA - RT	kg	l ₁ / l ₂	RS / RS RT / RT	kg	l ₁ / l ₂
28	1.1	0.03	63 / 40	4.0	0.04/0.08	28 / 28	2.5	0.03/0.03
40	2.5	0.08	63 / 50	5.3	0.04/0.13	28 / 40	3.9	0.03/0.08
50	3.8	0.13	63 / 60	8.0	0.04/0.20	28 / 50	5.2	0.03/0.13
60	6.5	0.20	71 / 50	6.6	0.06/0.13	28 / 60	7.9	0.03/0.20
70	9.0	0.35	71 / 60	9.3	0.06/0.20	40 / 70	12.0	0.08/0.35
85	13.5	0.60	71 / 70	11.8	0.06/0.35	40 / 85	16.5	0.08/0.60
110	39.0	1.50	71 / 85	16.3	0.06/0.60	50 / 110	45.0	0.13/1.50
*130	50.0	2.75	80 / 60	10.5	0.10/0.20	*60/130	57.0	0.25/2.75
*150	80.0	4.40	80 / 70	13.0	0.10/0.35	*70/150	90.0	0.35/4.40
			80 / 85	17.5	0.10/0.60			
			80 / 110	43.0	0.10/1.50			
			100/110	46.0	0.20/1.50			
			*100/130	64.0	0.20/2.75			
			*100/150	94.0	0.20/4.40			

* solo RS

XA	kg	l
63	1.5	0.04
71	2.2	0.06
80	3.0	0.10
100	7.0	0.20

Reductores Serie RS y RT

Cargas externas entrada

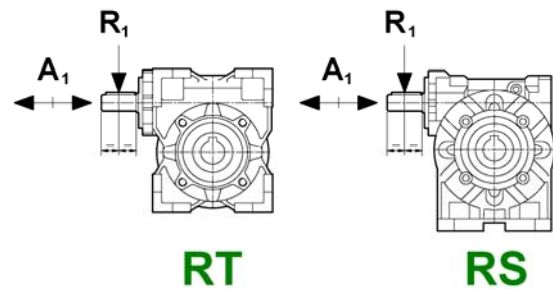

Cargas radiales de entrada R_1 [daN]

$$A_1 = 0,2 \times R_1$$

min ⁻¹	2800	1400	900	700	500	300
RS-RT 28	5	7	8	9	10	12
RS-RT 40	11	15	16	17	18	20
RS-RT 50	15	20	22	25	28	30
RS-RT 60	23	30	33	35	37	40
RS-RT 70	26	35	40	44	47	50
RS-RT 85	34	45	52	58	62	70
RS-RT 110	57	75	80	85	92	100
RS130	70	100	105	110	115	120
RS150	90	120	125	130	140	150

Reductores Serie RS y RT

Cargas externas salida

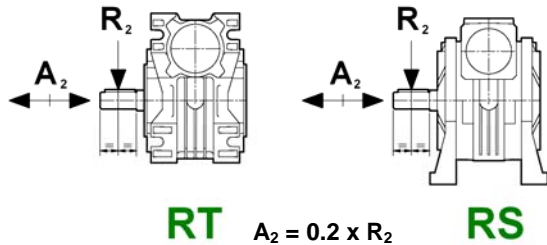

Cargas radiales de salida R_2 [daN] con rodamientos standard

min ⁻¹	280	200	140	93	70	50	35	29	25	20	18	14	Nr. rodam.
RS-RT 28	---	45	50	55	60	62	70	75	80	90	95	100	16005
RS-RT 40	100	100	110	120	135	150	160	170	180	190	200	230	16006
RS-RT 50	145	125	145	170	190	200	230	240	260	280	290	320	16008
RS-RT 60	225	240	250	290	330	360	390	430	320	500	420	560	①
RS-RT 70	260	270	290	360	390	420	450	520	550	590	630	670	②
RS-RT 85	330	330	370	440	470	540	550	630	660	710	750	830	③
RS-RT 110	---	390	415	520	540	590	570	750	780	800	880	980	④
RS 130	---	500	565	615	650	660	780	880	950	970	1050	1150	6015
RS 150	---	650	770	830	880	900	1100	1200	1250	1300	1400	1500	6216

① - RS: 6008 / RT: 6208

③ - RS: 6010 / RT: 6210

② - RS: 6009 / RT: 6209

④ - RS: 6012 / RT: 6212

Cargas radiales de salida R_2 [daN] con rodamientos reforzados

min ⁻¹	280	200	140	93	70	50	35	29	25	20	18	14	Nr. rodam.
RS-RT 28	---	65	75	82	90	93	105	112	120	130	130	130	6005
RS-RT 40	140	150	155	165	190	210	225	240	250	260	260	260	32006
RS-RT 50	200	175	200	240	260	300	340	360	390	420	420	420	32008
RS-RT 60	290	300	320	370	420	480	510	570	610	660	660	660	30208
RS-RT 70	335	330	370	450	516	560	610	690	730	790	790	790	⑤
RS-RT 85	410	420	460	550	630	720	730	840	870	940	940	940	⑥
RS-RT 110	---	500	540	670	750	800	930	1050	1110	1110	1110	1110	⑦
RS 130	---	700	790	860	970	990	1170	1290	1420	1450	1450	1450	32015
RS 150	---	900	1080	1160	1320	1350	1650	1800	1870	1950	1950	1950	30216

⑤ - RS: 32009 / RT: 30209

⑥ - RS: 32010 / RT: 30210

⑦ - RS: 32012 / RT: 30212

Reductores Serie RS y RT

FRS - FRT

Tamaños motores

FRS FRT	min ⁻¹ IEC	i = 5	i7	10	15	20	28	40	49	56	70	80	100
		280	200	140	93	70	50	35	29	25	20	18	14
28	56	---	⊙	⊙	⊙	⊙	⊙	⊙	⊙	⊙	⊙	⊙	⊙
	63	---	⊙	⊙	⊙	⊙	⊙	⊙	⊙	⊙	⊙	⊙	⊙
40	56	⊙	⊙	⊙	⊙	⊙	⊙	⊙	⊙	⊙	⊙	⊙	⊙
	63	⊙	⊙	⊙	⊙	⊙	⊙	⊙	⊙	⊙	⊙	⊙	⊙
	71	⊙	⊙	⊙	⊙	⊙	⊙	⊙	⊙	⊙	⊙	⊙	⊙
50	63	⊙	⊙	⊙	⊙	⊙	⊙	⊙	⊙	⊙	⊙	⊙	⊙
	71	⊙	⊙	⊙	⊙	⊙	⊙	⊙	⊙	⊙	⊙	⊙	⊙
	80	⊙	⊙	⊙	⊙	⊙	⊙	⊙	⊙	⊙	⊙	⊙	⊙
60	71	⊙	⊙	⊙	⊙	⊙	⊙	⊙	⊙	⊙	⊙	⊙	⊙
	80	⊙	⊙	⊙	⊙	⊙	⊙	⊙	⊙	⊙	⊙	⊙	⊙
	90	⊙	⊙	⊙	⊙	⊙	⊙	⊙	⊙	⊙	⊙	⊙	⊙
70	71	⊙	⊙	⊙	⊙	⊙	⊙	⊙	⊙	⊙	⊙	⊙	⊙
	80	⊙	⊙	⊙	⊙	⊙	⊙	⊙	⊙	⊙	⊙	⊙	⊙
	90	⊙	⊙	⊙	⊙	⊙	⊙	⊙	⊙	⊙	⊙	⊙	⊙
	100	⊙	⊙	⊙	⊙	⊙	⊙	⊙	⊙	⊙	⊙	⊙	⊙
85	80	⊙	⊙	⊙	⊙	⊙	⊙	⊙	⊙	⊙	⊙	⊙	⊙
	90	⊙	⊙	⊙	⊙	⊙	⊙	⊙	⊙	⊙	⊙	⊙	⊙
	100/112	⊙	⊙	⊙	⊙	⊙	⊙	⊙	⊙	⊙	⊙	⊙	⊙
110	90	---	⊙	⊙	⊙	⊙	⊙	⊙	⊙	⊙	⊙	⊙	⊙
	100/112	---	⊙	⊙	⊙	⊙	⊙	⊙	⊙	⊙	⊙	⊙	⊙
	132	---	○	○	○	○	○	○	○	○	○	○	○
*130	100/112	---	○	○	○	○	○	○	○	○	○	○	○
	132	---	○	○	○	○	○	○	---	---	---	---	---
*150	100/112	---	○	○	○	○	○	○	○	○	○	○	○
	132	---	○	○	○	○	○	○	○	○	○	---	---
	160	---	○	○	○	○	○	○	○	---	---	---	---

* nur RS

- ⊙ - B5 & B14 (Acoplamiento G)
- ⊙ - B5 (Acoplamiento G)
- - B5 & B14 (Agujero IEC)
- - B5 (Agujero IEC)

FRA - FTA

Reductores Serie RS y RT

Tamaños motores

FRA	IEC	i = 7	10	15	20	28	40	49	56	70	80	100
63/40	56 B5&B14	①	①	①	①	①	①	①	①	①	①	①
63/50		①	①	①	①	①	①	①	①	①	①	①
63/60		---	---	---	---	①	①	①	①	①	①	①
63/40	63 B5&B14	①	①	①	①	①	①	①	①	①	①	①
63/50		①	①	①	①	①	①	①	①	①	①	①
63/60		---	---	---	---	①	①	①	①	①	①	①
71/50	71 B5&B14	②	②	②	②	②	②	②	---	---	---	---
71/60		②	②	②	②	②	②	②	②	②	②	②
71/70		②	②	②	②	②	②	②	②	②	②	②
71/85		---	---	---	---	---	②	②	②	②	②	②
80/60	80 B5&B14	③	③	③	③	③	---	---	---	---	---	---
80/70		③	③	③	③	③	③	③	---	---	---	---
80/85		③	③	③	③	③	③	③	③	③	③	③
80/110		④	④	④	④	③	③	③	③	③	③	③
80/60	90 B5&B14	③	③	③	③	③	---	---	---	---	---	---
80/70		③	③	③	③	③	③	③	---	---	---	---
80/85		③	③	③	③	③	③	③	③	③	③	③
80/110		④	④	④	④	③	③	③	③	③	③	③
*100/110		④	④	④	④	③	③	③	③	③	③	③
*100/130	90 B5	⑤	⑤	⑤	⑤	⑤	⑤	⑤	⑤	⑤	⑤	⑤
	100 B5	⑤	⑤	⑤	⑤	⑤	⑤	⑤	⑤	⑤	⑤	⑤
*100/150	90 B5	⑥	⑥	⑥	⑤	⑤	⑤	⑤	⑤	⑤	⑤	⑤
	100 B5	⑥	⑥	⑥	⑤	⑤	⑤	⑤	⑤	⑤	⑤	⑤

* solo RS

* - Entrada reductor de un tren

** - Salida reductor de un tren & Entrada reductor FRS/FRT

① - ø105 x 14

② - ø120 x 19

③ - ø140 x 24

④ - ø140 x 28

⑤ - ø200 x 28

⑥ - ø200 x 28 (Agujero vis ø38 mm + Casquillo ø38/ø28)

Reductores Serie RS y RT

2800 min⁻¹

Tabla de selección

Tornillo sin fin RS - RT

RS RT	i =	5	7	10	15	20	28	40	49	56	70	80	100
	min ⁻¹	560	400	280	187	140	100	70	57	50	40	35	28
28	kW	---	0.63	0.49	0.35	0.25	0.23	0.16	0.13	0.12	0.09	0.08	0.04
	Nm	---	13	14	14	13	15	14	13	12	11	10	7
	eff.	---	0.86	0.83	0.79	0.77	0.69	0.64	0.61	0.54	0.49	0.49	0.46
40	kW	2.1	1,5	1,2	0,82	0,56	0,49	0,36	0,30	0,26	0,21	0,19	0,15
	Nm	32	31	34	34	30	34	32	31	30	29	28	26
	eff.	0.89	0,87	0,85	0,81	0,78	0,72	0,66	0,62	0,6	0,57	0,54	0,51
50	kW	3.8	3,0	2,0	1,5	0,95	0,92	0,63	0,51	0,43	0,33	0,31	0,23
	Nm	58	62	59	61	52	66	59	56	53	46	49	40
	eff.	0.90	0,88	0,86	0,82	0,8	0,75	0,69	0,66	0,64	0,58	0,58	0,52
60	kW	5.8	4,4	3,5	2,6	1,9	1,6	1,1	0,72	0,73	0,60	0,52	0,34
	Nm	90	93	104	110	108	116	105	85	92	92	85	68
	eff.	0.90	0,88	0,87	0,84	0,82	0,76	0,73	0,71	0,66	0,64	0,6	0,58
70	kW	8.1	5,7	4,3	3,2	2,4	2,2	1,5	1,2	1,0	0,80	0,69	0,54
	Nm	126	122	130	139	136	161	155	142	130	120	115	107
	eff.	0.91	0,89	0,88	0,85	0,83	0,78	0,74	0,7	0,68	0,63	0,61	0,58
85	kW	13.0	9,6	7,5	5,3	4,3	3,1	2,4	2,0	1,7	1,3	1,1	0,93
	Nm	202	205	225	234	237	235	250	242	229	210	200	190
	eff.	0.91	0,89	0,88	0,86	0,8	0,8	0,76	0,72	0,71	0,67	0,64	0,6
110	kW	---	17,5	14,8	10,7	8,6	7,0	5,0	4,5	3,6	3,1	3,0	2,1
	Nm	---	375	445	470	490	530	520	545	490	525	540	450
	eff.	---	0,9	0,88	0,86	0,84	0,79	0,76	0,73	0,71	0,7	0,67	0,62
*130	kW	---	26.3	21.6	15.8	12.2	9.4	7.7	6.0	5.3	3.9	3.3	2.4
	Nm	---	565	655	705	715	715	815	740	780	670	620	560
	eff.	---	0.9	0.89	0.87	0.86	0.8	0.78	0.74	0.77	0.72	0.68	0.68
*150	kW	---	37.0	29.6	22.8	17.1	13.6	10.7	8.5	6.6	5.5	4.9	3.6
	Nm	---	795	900	1015	1005	1065	1170	1090	970	950	915	845
	eff.	---	0.9	0.89	0.87	0.86	0.82	0.8	0.77	0.77	0.72	0.68	0.68

* solo RS

1400 min⁻¹

Reductores Serie RS y RT

Tornillo sin fin RS - RT

Tabla de selección

RS RT	i =	5	7	10	15	20	28	40	49	56	70	80	100
	min ⁻¹	280	200	140	93	70	50	35	29	25	20	18	14
28	kW	---	0,45	0,33	0,23	0,16	0,16	0,10	0,09	0,08	0,06	0,05	0,03
	Nm	---	18	18	18	16	20	17	17	15	12	12	8
	eff.	---	0.84	0.81	0.77	0.74	0.66	0.62	0.57	0.51	0.45	0.45	0.43
40	kW	1.5	1,1	0,81	0,55	0,38	0,37	0,25	0,21	0,18	0,14	0,12	0,09
	Nm	45	45	46	44	39	48	42	41	38	36	32	29
	eff.	0.87	0.85	0.83	0.78	0.75	0.68	0.61	0.58	0.56	0.52	0.50	0.46
50	kW	2.7	1,8	1,3	0,93	0,63	0,63	0,41	0,37	0,31	0,25	0,20	0,13
	Nm	81	75	75	74	65	85	72	76	71	63	58	43
	eff.	0.88	0.86	0.84	0.78	0.76	0.71	0.64	0.62	0.60	0.53	0.52	0.47
60	kW	4.1	2,8	2,3	1,6	1,2	1,0	0,75	0,62	0,54	0,46	0,37	0,25
	Nm	125	113	133	130	122	139	135	128	123	122	106	83
	eff.	0.89	0.86	0.84	0.81	0.77	0.71	0.66	0.62	0.60	0.55	0.53	0.49
70	kW	5.7	4,0	3,1	2,2	1,8	1,5	1,2	0,84	0,74	0,58	0,50	0,37
	Nm	176	166	180	188	194	216	238	189	180	163	154	130
	eff.	0.89	0.88	0.86	0.83	0.81	0.75	0.71	0.67	0.64	0.59	0.56	0.52
85	kW	9.1	6,2	4,6	3,4	2,9	2,2	2,0	1,4	1,2	0,96	0,86	0,55
	Nm	279	259	268	289	322	319	401	316	305	290	280	210
	eff.	0.90	0.88	0.86	0.83	0.82	0.76	0.72	0.67	0.68	0.63	0.60	0.56
110	kW	---	12,5	9,0	6,5	5,7	4,4	3,5	2,7	2,2	2,0	1,5	1,1
	Nm	---	525	532	560	647	642	691	631	595	635	525	469
	eff.	---	0.88	0.87	0.84	0.83	0.76	0.73	0.71	0.70	0.67	0.66	0.61
*130	kW	---	19.0	15.0	11.0	8,5	7,5	5,5	3,9	3,7	2,7	2,4	1,8
	Nm	---	807	890	960	975	1100	1140	950	1005	865	810	750
	eff.	---	0.89	0.87	0.85	0.84	0.77	0.76	0.72	0.71	0.67	0.63	0.61
*150	kW	---	24.9	21.0	16.0	12,5	9,5	8,0	5,9	5,1	3,8	3,3	2,6
	Nm	---	1060	1260	1410	1430	1435	1680	1440	1420	1230	1170	1120
	eff.	---	0.89	0.88	0.86	0.84	0.79	0.77	0.73	0.73	0.68	0.65	0.63

* solo RS

Reductores Serie RS y RT

900 min⁻¹

Tabla de selección

Tornillo sin fin RS - RT

RS RT	i =	5	7	10	15	20	28	40	49	56	70	80	100
	min ⁻¹	180	128	90	60	45	32	23	19	16	13	11	9
28	kW	---	0,36	0,24	0,18	0,13	0,12	0,08	0,07	0,06	0,04	0,03	0,02
	Nm	---	22	20	21	19	22	20	19	16	13	11	8
	eff.	---	0,82	0,78	0,72	0,70	0,61	0,56	0,52	0,45	0,43	0,40	0,37
40	kW	1,2	0,84	0,64	0,44	0,30	0,28	0,19	0,16	0,14	0,12	0,10	0,08
	Nm	54	52	54	52	45	52	46	43	41	40	39	36
	eff.	0,86	0,83	0,80	0,74	0,70	0,63	0,56	0,52	0,49	0,46	0,44	0,42
50	kW	2,1	1,5	1,1	0,75	0,52	0,51	0,35	0,28	0,25	0,19	0,17	0,12
	Nm	96	95	95	91	79	99	85	81	80	67	67	55
	eff.	0,86	0,85	0,81	0,76	0,72	0,65	0,58	0,56	0,54	0,47	0,46	0,42
60	kW	3,2	2,4	1,9	1,4	1,0	0,87	0,56	0,43	0,40	0,32	0,28	0,19
	Nm	150	150	163	166	161	175	152	135	130	125	115	94
	eff.	0,87	0,85	0,83	0,75	0,76	0,68	0,64	0,61	0,55	0,53	0,480	0,47
70	kW	4,5	3,2	2,4	1,7	1,3	1,2	0,87	0,64	0,53	0,42	0,38	0,30
	Nm	212	202	211	218	207	242	240	205	187	170	160	147
	eff.	0,88	0,86	0,83	0,79	0,77	0,70	0,654	0,62	0,59	0,54	0,50	0,46
85	kW	7,2	5,0	3,9	3,0	2,1	1,8	1,5	1,0	0,83	0,73	0,64	0,51
	Nm	338	320	350	378	355	373	410	350	332	300	290	260
	eff.	0,88	0,86	0,84	0,80	0,78	0,71	0,66	0,672	0,671	0,55	0,53	0,48
110	kW	---	9,8	8,0	5,7	4,4	3,7	2,7	2,3	1,9	1,7	1,5	0,94
	Nm	---	635	720	745	745	795	780	780	690	765	715	500
	eff.	---	0,87	0,85	0,82	0,79	0,73	0,68	0,64	0,62	0,59	0,57	0,50
*130	kW	---	14,9	11,7	8,4	6,5	5,1	4,1	3,1	2,8	2,1	1,8	1,3
	Nm	---	975	1070	1115	1115	1145	1215	1095	1145	960	890	805
	eff.	---	0,88	0,86	0,83	0,81	0,75	0,70	0,67	0,68	0,63	0,58	0,57
*150	kW	---	20,8	15,9	12,2	9,3	7,3	5,6	4,5	3,3	2,9	2,5	2,0
	Nm	---	1360	1470	1635	1625	1660	1740	1600	1370	1390	1290	1230
	eff.	---	0,88	0,87	0,84	0,82	0,77	0,73	0,69	0,69	0,64	0,61	0,58

* solo RS

700 min⁻¹

Reductores Serie RS y RT

Tornillo sin fin RS - RT

Tabla de selección

RS RT	i =	5	7	10	15	20	28	40	49	56	70	80	100
	min ⁻¹	140	100	70	47	35	25	18	15	13	10	8.7	7
28	kW	---	0,29	0,21	0,14	0,10	0,10	0,06	0,05	0,04	0,03	0,02	0,01
	Nm	---	23	23	22	21	24	21	20	17	13	11	8
	eff.	---	0.81	0.77	0.71	0.69	0.60	0.55	0.51	0.44	0.40	0.39	0.36
40	kW	1.00	0,74	0,54	0,39	0,26	0,24	0,17	0,14	0,12	0,10	0,09	0,07
	Nm	59	58	58	58	49	55	49	46	45	43	41	38
	eff.	0.85	0.82	0.79	0.73	0.68	0.59	0.53	0.50	0.48	0.44	0.42	0.39
50	kW	1.8	1,4	0,92	0,65	0,44	0,43	0,29	0,24	0,21	0,16	0,15	0,12
	Nm	106	110	100	99	86	106	91	87	83	70	72	62
	eff.	0.86	0.83	0.80	0.75	0.71	0.64	0.57	0.542	0.52	0.45	0.44	0.39
60	kW	2.8	2,0	1,6	1,1	0,87	0,73	0,49	0,35	0,34	0,26	0,24	0,17
	Nm	165	164	177	178	175	187	165	140	139	128	120	100
	eff.	0.87	0.84	0.81	0.77	0.74	0.67	0.62	0.59	0.54	0.51	0.46	0.44
70	kW	3.9	2,7	2,1	1,4	1,1	1,0	0,71	0,55	0,46	0,36	0,32	0,24
	Nm	234	216	233	231	225	256	245	220	197	176	167	150
	eff.	0.87	0.85	0.82	0.78	0.75	0.68	0.63	0.60	0.56	0.51	0.48	0.45
85	kW	6.2	4,6	3,5	2,5	1,9	1,5	1,2	0,93	0,78	0,59	0,56	0,44
	Nm	372	370	400	408	388	400	420	379	353	310	305	275
	eff.	0.87	0.85	0.83	0.79	0.76	0.69	0.65	0.61	0.59	0.55	0.50	0.46
110	kW	---	8,5	6,8	4,9	3,9	3,3	2,3	2,0	1,7	1,5	1,2	0,79
	Nm	---	700	780	795	815	890	820	840	770	815	720	515
	eff.	---	0.86	0.84	0.80	0.77	0.71	0.66	0.62	0.60	0.57	0.55	0.48
*130	kW	---	12,8	10,3	7,4	5,6	4,4	3,6	2,7	2,4	1,8	1,6	1,1
	Nm	---	1060	1200	1230	1215	1200	1320	1185	1215	1030	955	855
	eff.	---	0.87	0.85	0.81	0.80	0.72	0.68	0.65	0.66	0.61	0.56	0.55
*150	kW	---	18,0	13,7	10,6	8,1	6,2	4,9	3,8	3,0	2,6	2,3	1,7
	Nm	---	1475	1610	1805	1780	1790	1890	1710	1535	1500	1425	1275
	eff.	---	0.87	0.86	0.83	0.81	0.75	0.71	0.68	0.67	0.61	0.58	0.56

* solo RS

Reductores Serie RS y RT

1400 min⁻¹

Tabla de selección

Tornillo sin fin y engranajes RA - TA

	$i_1 =$	3.5	6.3	8	<p>$A_2 = 0.2 \times R_2$</p> <p>Dimensiones: página 44</p>								
	min ⁻¹	400	225	175									
XA63	kW	0.50	0.23	0.18									
	Nm	12	10	9									
	R ₂ [N]	390	450	450									
XA71	kW	1.1	0.52	0.37									
	Nm	26	22	20									
	R ₂ [N]	490	560	560									
XA80	kW	3.1	1.5	1.1									
	Nm	68	65	60									
	R ₂ [N]	610	700	700									
XA100	kW	8.7	4.0	2.2									
	Nm	235	163	136									
	R ₂ [N]	1500	2500	2500									
$i_1 = 3.5$	$i = i_1 \times i_2$	25	35	53	70	98	140	172	196	245	280	350	
	min ⁻¹	57	40	27	20	14	10	8	7	6	5	4	
	i_2	7	10	15	20	28	40	49	56	70	80	100	
63/40	kW	0.55	0.40	0.28	0.20	0.19	0.13	0.11	0.10	0.06	0.05	0.03	
	Nm	72	72	70	60	70	64	58	56	42	35	25	
	eff.	0.78	0.75	0.70	0.63	0.56	0.50	0.46	0.44	0.41	0.40	0.35	
63/50	kW	1.02	0.70	0.50	0.33	0.32	0.21	0.20	0.16	0.11	0.09	0.06	
	Nm	135	127	125	105	125	105	115	100	80	70	50	
	eff.	0.79	0.76	0.70	0.66	0.59	0.52	0.50	0.46	0.42	0.40	0.35	
63/60	kW	1.53	1.18	0.83	0.57	0.53	0.33	0.27	0.23	0.19	0.15	0.10	
	Nm	205	217	215	192	217	177	170	152	145	110	85	
	eff.	0.80	0.77	0.72	0.70	0.61	0.57	0.54	0.49	0.45	0.38	0.36	
71/70	kW	1.96	1.48	1.08	0.77	0.72	0.50	0.43	0.36	0.30	0.26	0.19	
	Nm	265	275	285	260	310	270	270	235	225	200	180	
	eff.	0.81	0.78	0.74	0.71	0.64	0.57	0.54	0.49	0.45	0.41	0.39	
71/85	kW	3.14	2.39	1.77	1.37	1.11	0.80	0.65	0.58	0.49	0.40	0.26	
	Nm	430	450	475	470	475	445	420	410	390	340	250	
	eff.	0.82	0.79	0.75	0.72	0.64	0.58	0.55	0.53	0.48	0.44	0.40	
80/110	kW	6.02	4.63	3.58	2.61	2.18	1.60	1.27	1.12	0.86	0.86	0.54	
	Nm	835	895	950	910	960	950	850	820	750	740	540	
	eff.	0.83	0.81	0.74	0.73	0.66	0.62	0.57	0.55	0.52	0.45	0.42	
RA	kW	7.0	6.8	5.5	3.8	3.1	2.3	1.7	1.5	1.3	1.1	0.8	
	Nm	975	1320	1495	1350	1430	1380	1300	1250	1200	1080	880	
	eff.	0.83	0.81	0.77	0.75	0.67	0.63	0.64	0.62	0.60	0.50	0.48	
RA	kW	7.9	7.8	7.5	5.7	4.5	3.3	2.7	2.4	1.8	1.6	1.0	
	Nm	1115	1535	2090	2060	2130	2050	2040	2025	1700	1459	1200	
	eff.	0.84	0.82	0.79	0.76	0.69	0.66	0.64	0.62	0.60	0.52	0.50	

1400 min⁻¹

Reductores Serie RS y RT

Tornillo sin fin y engranajes RA - TA

Tabla de selección

i₁ = 6.3	i = i₁ x i₂	44	63	95	126	176	252	309	353	441	504	630
	min⁻¹	32	22	15	11	8	5.5	4.6	4	3.2	2.8	2.2
	i₂	7	10	15	20	28	40	49	56	70	80	100
63/40	kW	0.35	0.25	0.17	0.12	0.11	0.08	0.06	0.06	0.05	0.04	0.03
	Nm	79	78	74	63	69	63	57	55	53	51	46
	eff.	0.76	0.72	0.67	0.60	0.52	0.45	0.43	0.39	0.35	0.34	0.31
63/50	kW	0.62	0.42	0.30	0.20	0.20	0.14	0.11	0.10	0.09	0.07	0.05
	71/50 Nm	145	133	130	113	138	115	108	100	92	89	72
	eff.	0.78	0.74	0.67	0.63	0.55	0.48	0.45	0.42	0.36	0.36	0.31
63/60	kW	0.92	0.74	0.52	0.40	0.35	0.23	0.16	0.16	0.11	0.10	0.08
	71/60 Nm	218	237	235	230	238	210	160	175	141	130	122
	80/60 eff.	0.79	0.75	0.70	0.67	0.57	0.53	0.49	0.45	0.42	0.37	0.35
71/70	kW	1.2	0.95	0.68	0.50	0.44	0.32	0.26	0.23	0.18	0.17	0.12
	80/70 Nm	289	310	310	292	320	295	272	254	221	210	190
	eff.	0.80	0.76	0.71	0.68	0.60	0.54	0.50	0.46	0.42	0.37	0.36
71/85	kW	2.0	1.6	1.1	0.84	0.69	0.53	0.43	0.37	0.28	0.26	0.22
	80/85 Nm	490	526	516	495	501	500	466	449	391	380	345
	eff.	0.80	0.77	0.72	0.69	0.60	0.55	0.51	0.50	0.46	0.42	0.36
80/110	kW	4.3	3.2	2.4	1.8	1.6	1.1	1.0	0.80	0.66	0.51	0.32
	100/110 Nm	1030	1100	1150	100	1170	1110	1100	995	950	780	550
	eff.	0.81	0.79	0.74	0.71	0.63	0.57	0.53	0.52	0.48	0.45	0.39
100/130	kW	6.41	4.94	3.72	2.71	2.37	1.65	1.47	1.25	1.02	0.82	0.47
	Nm	1600	1700	1800	1700	1800	1700	1700	1600	1600	1300	900
	eff.	0.83	0.80	0.75	0.73	0.63	0.60	0.55	0.53	0.52	0.46	0.45
100/150	kW	8.41	6.61	5.04	3.77	3.02	2.31	1.82	1.41	1.24	1.09	0.84
	Nm	2100	2300	2500	2400	2400	2500	2300	2000	1800	1800	1700
	eff.	0.83	0.81	0.77	0.74	0.66	0.63	0.60	0.59	0.81	0.48	0.47

Reductores Serie RS y RT

1400 min⁻¹

Tabla de selección

Tornillo sin fin y engranajes RA - TA

$i_1 = 8$	$i = i_1 \times i_2$ min ⁻¹	56	80	120	160	224	320	392	448	560	640	800
	i_2	25	18	12	9	6	4	3.5	3	2.5	2.2	1.75
		7	10	15	20	28	40	49	56	70	80	100
63/40	kW	0.32	0.23	0.16	0.11	0.11	0.08	0.06	0.05	0.03	0.03	0.02
	Nm	93	89	84	72	85	75	69	59	45	38	27
	eff.	0.75	0.72	0.65	0.59	0.50	0.44	0.41	0.38	0.36	0.34	0.31
63/50	kW	0.58	0.41	0.28	0.20	0.18	0.13	0.10	0.09	0.06	0.05	0.03
	Nm	170	165	154	130	150	130	120	115	86	73	53
	eff.	0.77	0.73	0.67	0.61	0.55	0.47	0.45	0.41	0.36	0.37	0.31
63/60	kW	0.87	0.68	0.49	0.34	0.31	0.21	0.16	0.15	0.10	0.08	0.05
	Nm	260	280	275	240	270	235	220	200	155	125	92
	eff.	0.78	0.75	0.69	0.65	0.57	0.51	0.50	0.43	0.41	0.37	0.35
71/70	kW	1.26	0.88	0.63	0.44	0.48	0.28	0.24	0.20	0.16	0.12	0.05
	Nm	380	365	360	325	440	320	320	275	245	200	145
	eff.	0.79	0.76	0.70	0.67	0.60	0.53	0.50	0.45	0.41	0.38	0.35
71/85	kW	1.76	1.42	1.07	0.85	0.65	0.48	0.40	0.33	0.26	0.20	0.13
	Nm	530	595	620	620	600	560	550	510	450	360	260
	eff.	0.79	0.77	0.71	0.67	0.60	0.54	0.52	0.50	0.45	0.41	0.37
80/110	kW	3.42	2.75	1.97	1.52	1.29	0.97	0.73	0.64	0.52	0.43	0.27
	Nm	1045	1170	1180	1160	1200	1180	1020	980	920	850	550
	eff.	0.80	0.78	0.73	0.70	0.61	0.56	0.52	0.50	0.46	0.45	0.38
RA 100/130	kW	3.3	3.0	3.2	2.3	1.8	1.2	1.1	0.9	0.7	0.7	0.5
	Nm	1000	1240	1840	1765	1760	1700	1660	1600	1435	1330	1160
	eff.	0.80	0.78	0.73	0.72	0.62	0.58	0.56	0.54	0.51	0.45	0.43
RA 100/150	kW	3.7	3.4	3.6	3.4	2.7	2.0	1.7	1.4	1.1	1.0	0.8
	Nm	1130	1425	2150	2580	2675	2860	2550	2490	2110	1970	1855
	eff.	0.81	0.79	0.75	0.72	0.63	0.61	0.56	0.57	0.49	0.46	0.45

1400 min⁻¹

Reductores Serie RS y RT

Reductores de doble tornillo sin fin RS/RS - RT/RT

Tabla de selección

RS/RS RT/RT	$i = i_1 \times i_2$	420	560	784	1120	1568	2240	2800	4000	5600	8000	10000
	min ⁻¹	3.3	2.5	1.8	1.25	0.9	0.6	0.5	0.35	0.25	0.17	0.14
	$i_1 =$ $i_2 =$	15 28	20 28	28 28	40 28	56 28	56 40	70 40	100 40	100 56	100 80	100 100
28/28	W	32	25	21	16	13	9	8	6	3	1.8	1.3
	Nm	35	36	36	36	35	30	30	30	16	12	11
	eff.	0.38	0.37	0.32	0.30	0.25	0.21	0.20	0.18	0.14	0.12	0.13
28/40	W	75	60	46	34	30	22	22	14	11	5	3
	Nm	85	85	80	80	80	73	76	70	62	41	25
	eff.	0.39	0.37	0.33	0.31	0.25	0.21	0.18	0.18	0.15	0.14	0.12
28/50	W	133	106	91	74	60	36	36	28	20	10	6
	Nm	150	150	160	175	160	125	131	147	125	78	49
	eff.	0.39	0.37	0.33	0.31	0.25	0.22	0.19	0.19	0.16	0.14	0.12
28/60	W	197	157	132	91	91	67	54	30	32	16	10
	Nm	240	240	245	230	260	245	217	164	195	128	91
	eff.	0.42	0.40	0.35	0.33	0.27	0.23	0.21	0.20	0.16	0.14	0.13
40/70	W	298	249	198	157	119	86	72	60	42	24	16
	Nm	380	400	400	395	380	370	345	360	321	201	154
	eff.	0.44	0.42	0.38	0.33	0.30	0.27	0.25	0.22	0.20	0.15	0.14
40/85	W	447	372	276	224	180	138	120	90	72	39	26
	Nm	595	625	585	625	610	615	595	565	550	373	264
	eff.	0.46	0.44	0.40	0.35	0.32	0.28	0.26	0.23	0.20	0.17	0.15
50/110	W	865	756	579	453	382	292	235	163	128	82	51
	Nm	1190	1300	1300	1280	1350	1340	1210	1070	980	810	560
	eff.	0.48	0.45	0.42	0.37	0.33	0.30	0.27	0.24	0.20	0.18	0.16
RS/RS 60/130	kW	1.5	1.1	0.75	0.55	0.55	0.37	0.25	0.25	0.25	0.25	0.25
	Nm	2015	1930	1670	1530	2015	1830	1410	1770	1850	1420	1225
	eff.	0.50	0.46	0.43	0.40	0.35	0.33	0.30	0.27	0.25	0.21	0.20
RS/RS 70/150	kW	1.8	1.5	1.1	0.75	0.75	0.55	0.37	0.37	0.25	0.25	0.25
	Nm	2570	2830	2570	2460	2850	3020	2325	2875	2670	2135	1995
	eff.	0.52	0.50	0.46	0.43	0.39	0.36	0.33	0.31	0.27	0.23	0.22

Reductores Serie RS y RT

1400 min⁻¹

Tabla de selección

Motoreductores

0.06 kW						0.09 kW					
	min ⁻¹	i =	Nm	SF	kg		min ⁻¹	i =	Nm	SF	kg
MRS-MRT 28	200	7	2.4	>3	3.6	MRS-MRT 40/85	0.4	4000	565	1.0	19
MRS-MRT 28	140	10	3.3	>3	3.6	MRS-MRT 40/85	0.3	5600	688	0.8	19
MRS-MRT 28	93	15	4.7	>3	3.6	0.12 kW					
MRS-MRT 28	70	20	6.1	2.6	3.6		min ⁻¹	i =	Nm	SF	kg
MRS-MRT 28	50	28	7.6	2.6	3.6	MRS-MRT 28	200	7	4.8	>3	4.8
MRS-MRT 28	35	40	10	1.7	3.6	MRS-MRT 28	140	10	6.6	2.7	4.8
MRA-MTA 63/40	32	44	14	>3	6.5	MRS-MRT 28	93	15	9.5	1.9	4.8
MRS-MRT 28	29	49	11	1.5	3.6	MRS-MRT 28	70	20	12	1.3	4.8
MRS-MRT 28	25	56	12	1.3	3.6	MRS-MRT 28	50	28	15	1.3	4.8
MRA-MTA 63/40	22	63	19	>3	6.5	MRS-MRT 40	35	40	20	2.1	6.2
MRS-MRT 28	20	70	13	0.9	3.6	MRA-MTA 63/40	32	44	27	2.9	7.7
MRS-MRT 40	18	80	16	2.0	5.0	MRS-MRT 40	29	49	23	1.8	6.2
MRA-MTA 63/40	15	95	26	2.8	6.5	MRS-MRT 40	25	56	26	1.5	6.2
MRS-MRT 40	14	100	19	1.5	5.0	MRA-MTA 63/40	22	63	37	2.1	7.7
MRA-MTA 63/40	11	126	31	2.0	6.5	MRS-MRT 40	20	70	30	1.2	6.2
MRS-MRT 28/28	9.3	150	31	1.1	5.0	MRS-MRT 40	18	80	33	1.0	6.2
MRA-MTA 63/40	8.0	176	37	1.8	6.5	MRA-MTA 63/40	15	95	52	1.4	7.7
MRS-MRT 28/28	7.0	200	30	0.8	5.0	MRS-MRT 50	14	100	38	1.1	7.5
MRA-MTA 63/40	5.5	252	46	1.4	6.5	MRA-MTA 63/40	11	126	62	1.0	7.7
MRS-MRT 28/28	5.0	280	35	0.8	5.0	MRS-MRT 28/40	9.3	150	64	1.4	7.6
MRA-MTA 63/40	4.6	309	54	1.0	6.5	MRA-MTA 63/40	8.0	176	75	0.9	7.7
MRA-MTA 63/40	4.0	353	56	1.0	6.5	MRS-MRT 28/40	7.0	200	77	1.0	7.6
MRS-MRT 28/40	3.3	420	67	1.3	6.4	MRA-MTA 63/50	5.5	252	99	1.2	9.0
MRA-MTA 63/50	3.2	441	65	1.4	7.8	MRS-MRT 28/40	5.0	280	94	0.8	7.6
MRA-MTA 63/50	2.8	504	74	1.2	7.8	MRA-MTA 63/50	4.6	309	114	0.9	9.0
MRS-MRT 28/40	2.5	560	85	1.0	6.4	MRS-MRT 28/50	3.3	420	134	1.2	8.9
MRA-MTA 63/50	2.2	630	80	0.9	7.8	MRS-MRT 28/50	2.5	560	170	0.9	8.9
MRS-MRT 28/50	1.8	784	106	1.5	7.7	MRS-MRT 28/60	1.8	784	225	1.1	12
MRS-MRT 28/50	1.3	1120	142	1.2	7.7	MRS-MRT 28/60	1.3	1120	303	0.8	12
MRS-MRT 28/50	0.9	1568	160	1.0	7.7	MRS-MRT 40/70	0.9	1568	385	1.0	16
MRS-MRT 28/60	0.6	2240	211	1.2	10	MRS-MRT 40/85	0.6	2240	513	1.2	20
MRS-MRT 28/60	0.5	2800	241	0.9	10	MRS-MRT 40/85	0.5	2800	596	1.0	20
MRS-MRT 40/70	0.4	4000	360	1.0	15	MRS-MRT 40/85	0.4	4000	753	0.8	20
MRS-MRT 40/70	0.3	5600	458	0.7	15	0.18 kW					
MRS-MRT 40/85	0.2	8000	557	0.7	19		min ⁻¹	i =	Nm	SF	kg
MRS-MRT 40/110	0.1	10000	614	0.4	19	MRS-MRT 28	200	7	7.2	2.5	5.4
0.09 kW						MRS-MRT 28	140	10	9.9	1.8	5.4
	min ⁻¹	i =	Nm	SF	kg	MRS-MRT 28	93	15	14	1.3	5.4
MRS-MRT 28	200	7	3.6	>3	3.7	MRS-MRT 40	70	20	18	2.1	6.8
MRS-MRT 28	140	10	5.0	>3	3.7	MRS-MRT 40	50	28	23	2.1	6.8
MRS-MRT 28	93	15	7.1	2.5	3.7	MRS-MRT 40	35	40	30	1.4	6.8
MRS-MRT 28	70	20	9.1	1.8	3.7	MRA-MTA 63/40	32	44	41	1.9	8.3
MRS-MRT 28	50	28	11	1.8	3.7	MRS-MRT 40	29	49	35	1.2	6.8
MRS-MRT 28	35	40	15	1.1	3.7	MRS-MRT 40	25	56	39	1.0	6.8
MRA-MTA 63/40	32	44	21	>3	6.6	MRA-MTA 63/40	22	63	56	1.4	8.3
MRS-MRT 28	29	49	17	1.0	3.7	MRS-MRT 50	20	70	46	1.4	8.1
MRS-MRT 40	25	56	20	2.1	5.1	MRS-MRT 50	18	80	51	1.1	8.1
MRA-MTA 63/40	22	63	28	2.8	6.6	MRA-MTA 63/40	15	95	78	0.9	8.3
MRS-MRT 40	20	70	22	1.6	5.1	MRA-MTA 63/50	11	126	97	1.2	9.6
MRS-MRT 40	18	80	25	1.3	5.1	MRS-MRT 28/50	9.3	150	93	1.6	9.5
MRA-MTA 63/40	15	95	39	1.9	6.6	MRA-MTA 63/50	8.0	176	119	1.2	9.6
MRS-MRT 40	14	100	28	1.0	5.1	MRS-MRT 28/50	7.0	200	120	1.1	9.5
MRA-MTA 63/40	11	126	46	1.4	6.6	MRS-MRT 28/50	5.0	280	141	1.1	9.5
MRS-MRT 28/40	9.3	150	48	1.3	6.5	MRS-MRT 28/60	3.3	420	217	1.1	12
MRA-MTA 63/40	8.0	176	56	1.2	6.6	MRS-MRT 40/70	2.5	560	289	1.4	16
MRS-MRT 28/40	7.0	200	60	1.3	6.5	MRS-MRT 40/70	1.8	784	366	1.1	16
MRA-MTA 63/40	5.5	252	70	0.9	6.6	MRS-MRT 40/85	1.3	1120	481	1.3	21
MRS-MRT 28/40	5.0	280	70	1.0	6.5	MRS-MRT 40/85	0.9	1568	616	1.0	21
MRA-MTA 63/50	4.6	309	86	1.3	7.9	MRS-MRT 40/85	0.6	2240	770	0.8	21
MRA-MTA 63/50	4.0	353	91	1.1	7.9	0.25 kW					
MRS-MRT 28/50	3.3	420	101	1.5	7.8		min ⁻¹	i =	Nm	SF	kg
MRA-MTA 63/50	3.2	441	97	0.9	7.9	MRS-MRT 40	280	5	7.5	>3	8.3
MRS-MRT 28/50	2.5	560	127	1.2	7.8	MRS-MRT 40	200	7	10	>3	8.3
MRS-MRT 28/50	1.8	784	159	1.0	7.8	MRS-MRT 40	140	10	14	>3	8.3
MRS-MRT 28/50	1.3	1120	213	0.8	7.8	MRS-MRT 40	93	15	20	2.2	8.3
MRS-MRT 28/60	0.9	1568	260	1.0	11	MRS-MRT 40	70	20	26	1.5	8.3
MRS-MRT 40/70	0.6	2240	371	1.0	15	MRS-MRT 40	50	28	32	1.5	8.3
MRS-MRT 40/85	0.5	2800	447	1.3	19	MRS-MRT 40	35	40	42	1.0	8.3

1400 min⁻¹

Reductores Serie RS y RT

Motoreductores

Tabla de selección

0.25 kW						0.55 kW					
	min ⁻¹	i =	Nm	SF	kg		min ⁻¹	i =	Nm	SF	kg
MRA-MTA 71/50	32	44	59	2.5	12	MRA-MTA 80/85	8.0	176	396	1.3	26
MRS-MRT 50	29	49	52	1.5	9.6	MRA-MTA 80/85	5.5	252	520	1.0	26
MRS-MRT 50	25	56	57	1.3	9.6	MRA-MTA	4.6	309	614	1.8	49
MRA-MTA 71/50	22	63	80	1.7	12	MRA-MTA	4.0	353	689	1.4	49
MRS-MRT 50	20	70	63	1.0	9.6	MRS-MRT	3.3	420	756	1.1	49
MRS-MRT 60	18	80	72	1.5	12	MRA-MTA	3.2	441	794	1.2	49
MRA-MTA 71/50	95	95	109	1.2	12	MRA-MTA	2.8	504	851	0.9	49
MRS-MRT 60	14	100	88	1.0	12	MRS-MRT	2.5	570	962	1.3	49
MRA-MTA 71/60	11	126	144	1.6	15	MRS-MRT	1.8	784	1235	1.5	49
MRS-MRT 40/70	9.3	150	146	1.5	18						
MRA-MTA 71/60	8.0	176	171	1.4	15	0.75 kW					
MRS-MRT 40/70	7.0	200	188	1.5	18		min ⁻¹	i =	Nm	SF	kg
MRA-MTA 71/70	5.5	252	232	1.3	18	MRS-MRT 50	280	5	23	>3	14
MRS-MRT 40/70	5.0	280	224	1.5	18	MRS-MRT 50	200	7	31	2.4	14
MRA-MTA 71/70	4.6	309	263	1.0	18	MRS-MRT 50	140	10	43	1.7	14
MRA-MTA 71/70	4.0	353	277	0.9	18	MRS-MRT 50	93	15	60	1.2	14
MRS-MRT 40/70	3.3	420	315	1.2	18	MRS-MRT 60	70	20	79	1.5	17
MRS-MRT 40/70	2.5	560	401	1.0	18	MRS-MRT 60	50	28	102	1.4	17
MRS-MRT 40/85	1.8	784	535	1.1	22	MRS-MRT 60	35	40	135	1.0	17
MRS-MRT 50/110	1.3	1120	707	1.8	46	MRA-MTA 80/60	32	44	178	1.2	20
MRS-MRT 50/110	0.9	1568	882	1.5	46	MRS-MRT 70	29	49	168	1.1	19
MRS-MRT 50/110	0.6	2240	1146	1.2	46	MRS-MRT 70	25	56	183	1.0	19
MRS-MRT 50/110	0.5	2800	1289	0.9	46	MRA-MTA 80/60	22	63	242	1.0	20
						MRS-MRT 85	20	70	226	1.3	23
0.37 kW											
	min ⁻¹	i =	Nm	SF	kg	MRS-MRT 85	18	80	246	1.1	23
MRS-MRT 40	280	5	11	>3	8.7	MRA-MTA 80/70	11	126	341	0.9	23
MRS-MRT 40	200	7	15	3.0	8.7	MRA-MTA 80/85	8.0	176	540	0.9	27
MRS-MRT 40	140	10	21	2.2	8.7	MRA-MTA	5.5	252	735	1.5	50
MRS-MRT 40	93	15	30	1.5	8.7	MRA-MTA	4.6	309	838	1.3	50
MRS-MRT 40	70	20	38	1.0	8.7	MRA-MTA	4.0	353	939	1.1	50
MRS-MRT 40	50	28	48	1.0	8.7	MRS-MRT	3.3	420	1031	1.2	50
MRS-MRT 50	35	40	65	1.1	10	MRA-MRT	3.2	441	1083	0.9	50
MRA-MTA 71/50	32	44	87	1.7	13	MRS-MRT	2.5	570	1289	1.0	50
MRS-MRT 50	29	49	77	1.0	10	1.1 kW					
MRS-MRT 60	25	56	85	1.5	13		min ⁻¹	i =	Nm	SF	kg
MRA-MTA 71/50	22	63	118	1.1	13	MRS-MRT 60	280	5	34	>3	19
MRS-MRT 60	20	70	97	1.3	13	MRS-MRT 60	200	7	45	2.5	19
MRS-MRT 60	18	80	107	1.0	13	MRS-MRT 60	140	10	63	2.1	19
MRA-MTA 71/60	15	95	168	1.4	16	MRS-MRT 60	93	15	91	1.4	19
MRS-MRT 70	14	100	130	1.0	15	MRS-MRT 60	70	20	116	1.1	19
MRA-MTA 71/60	11	126	213	1.1	15	MRS-MRT 70	50	28	158	1.4	21
MRS-MRT 40/70	9.3	150	217	2.1	18	MRS-MRT 70	35	40	213	1.1	21
MRA-MTA 71/60	8.0	176	253	0.9	15	MRA-MTA 80/70	32	44	264	1.1	25
MRS-MRT 40/70	7.0	200	278	1.3	18	MRS-MRT 85	29	49	246	1.3	26
MRA-MTA 71/70	5.5	252	343	0.9	18	MRS-MRT 85	25	56	286	1.1	26
MRS-MRT 40/70	5.0	280	332	1.1	18	MRA-MTA 80/85	22	63	364	1.4	30
MRS-MRT 40/85	3.3	420	488	1.2	23	MRS-MRT 110	20	70	352	1.8	48
MRS-MRT 40/85	2.5	560	622	1.0	23	MRS-MRT 110	18	80	396	1.3	48
MRS-MRT 50/110	1.3	1120	1046	1.2	47	MRA-MTA 80/85	15	95	513	1.0	30
MRS-MRT 50/110	0.9	1568	1306	1.1	47	MRS-MRT 110	14	100	458	1.0	48
						MRA-MTA	11	126	671	1.6	52
0.55 kW						MRA-MTA	8.0	176	832	1.4	52
	min ⁻¹	i =	Nm	SF	kg	MRA-MRT	5.5	252	1078	1.0	52
MRS-MRT 40	280	5	16	2.8	10.7	MRA-MTA	4.6	309	1229	0.9	52
MRS-MRT 50	200	7	23	>3	12	MRA 100/130	3.5	400	1681	1.0	76
MRS-MRT 50	140	10	32	2.4	12	MRS-MRT	3.3	420	1576	1.3	69
MRS-MRT 50	93	15	44	1.7	12	MRA 100/150	3.0	448	1916	1.3	106
MRS-MRT 50	70	20	57	1.1	12	MRA 100/150	2.5	560	2059	1.0	106
MRS-MRT 50	50	28	75	1.1	12	MRA 100/150	2.2	640	2209	0.9	106
MRS-MRT 60	35	40	99	1.4	15	MRS-MRT 70/150	1.8	784	2706	0.9	102
MRA-MTA 80/60	32	44	130	1.7	19	1.5 kW					
MRS-MRT 60	29	49	114	1.1	15		min ⁻¹	i =	Nm	SF	kg
MRS-MRT 60	25	56	126	1.0	15	MRS-MRT 60	280	5	46	2.7	20
MRA-MTA 80/60	22	63	177	1.2	19	MRS-MRT 60	200	7	62	1.8	20
MRS-MRT 70	20	70	155	1.1	18	MRS-MRT 60	140	10	86	1.5	20
MRS-MRT 70	18	80	168	1.0	18	MRS-MRT 60	93	15	124	1.0	20
MRA-MTA 80/60	15	95	249	1.0	19	MRS-MRT 70	70	20	166	1.2	23
MRS-MRT 85	14	100	210	1.0	22	MRS-MRT 70	50	28	215	1.0	23
MRA-MTA 80/70	11	126	321	1.1	22	MRS-MRT 85	35	40	295	1.4	27

Reductores Serie RS y RT

1400 min⁻¹

Tabla de selección

Motoreductores

1.5 kW						4.0 kW					
	min ⁻¹	i =	Nm	SF	kg		min ⁻¹	i =	Nm	SF	kg
MRA-MTA 80/85	32	44	360	1.4	31	MRS 150	25	56	1115	1.3	130
MRS-MRT 85	29	49	336	0.9	27	MRS 150	20	70	1299	0.9	130
MRS-MRT 110	29	49	356	1.8	50	MRA 100/130	20	70	1433	0.9	93
MRS-MRT 110	25	56	401	1.5	50	MRA 100/150	18	80	1724	0.9	123
MRA-MTA 80/85	22	63	496	1.1	31	MRA 100/150	14	98	1845	1.2	123
MRS-MRT 110	20	70	480	1.3	50	MRA 100/150	12	120	2456	0.9	123
MRS-MRT 110	18	80	540	1.0	50						
MRA-MTA 80/110	15	95	719	1.6	54	5.5 kW					
MRS 130	14	100	624	1.2	64		min ⁻¹	i =	Nm	SF	kg
MRA-MTA 80/110	11	126	915	1.2	54	MRS-MRT 110	200	7	231	2.3	79
MRA-MTA 80/110	8.0	176	1135	1.0	54	MRS-MRT 110	140	10	326	1.6	79
MRA 100/130	7.0	200	1269	1.0	78	MRS-MRT 110	93	15	473	1.2	79
MRA 100/130	6.3	224	1421	1.2	78	MRS-MRT 110	70	20	623	1.0	79
MRA 100/150	5.0	280	1490	1.1	108	MRS 130	50	28	809	1.4	93
MRA 100/150	3.5	400	2292	1.1	108	MRS 130	35	40	1141	1.0	93
MRA 100/150	3.0	448	2613	1.0	108	MRS 150	29	49	1342	1.1	123
						MRA 100/130	27	53	1531	1.0	107
						MRS 150	25	56	1534	0.9	123
2.2 kW						7.5 kW					
	min ⁻¹	i =	Nm	SF	kg		min ⁻¹	i =	Nm	SF	kg
MRS-MRT 70	280	5	92	1.9	28	MRS-MRT 110	200	7	315	1.7	88
MRS-MRT 70	200	7	92	1.8	28	MRS-MRT 110	140	10	445	1.2	88
MRS-MRT 70	140	10	129	1.4	28	MRS-MRT 110	93	15	645	0.9	88
MRS-MRT 70	93	15	187	1.0	28	MRS 130	93	15	652	1.5	102
MRS-MRT 85	70	20	246	1.3	33	MRS 130	70	20	860	1.1	102
MRS-MRT 85	50	28	319	1.0	33	MRS 130	50	28	1103	1.0	102
MRS-MRT 110	35	40	438	1.6	55	MRS 150	35	40	1576	1.1	132
MRS-MRT 110	29	49	522	1.2	55	MRA 100/130	26	53	1041	1.4	116
MRS-MRT 110	25	56	588	1.0	55	MRA 100/150	25	56	1036	1.1	146
MRS-MRT 110	20	70	704	0.9	55						
MRS 130	18	80	756	1.1	69	11 kW					
MRS 150	14	100	945	1.2	99		min ⁻¹	i =	Nm	SF	kg
MRA 100/130	14	98	985	1.5	83	MRS 150	200	7	467	2.3	148
MRA 100/130	12	125	1369	1.3	83	MRS 150	140	10	660	1.9	148
MRA 100/130	10	140	1324	1.0	83	MRS 150	93	15	968	1.5	148
MRA 100/130	8.9	160	1729	1.0	83	MRS 150	70	20	1261	1.1	148
MRA 100/150	7.0	200	1861	1.1	113	MRS 150	50	28	1660	0.9	148
MRA 100/150	6.3	230	2175	1.2	113						
3.0 kW						15 kW					
	min ⁻¹	i =	Nm	SF	kg		min ⁻¹	i =	Nm	SF	kg
MRS-MRT 70	280	5	91	1.9	30	MRS 150	200	7	637	1.7	158
MRS-MRT 70	200	7	126	1.3	30	MRS 150	140	10	900	1.4	158
MRS-MRT 70	140	10	176	1.0	30	MRS 150	93	15	1320	1.1	158
MRS-MRT 85	93	15	255	1.1	35						
MRS-MRT 85	70	20	336	1.0	35						
MRS-MRT 110	50	28	435	1.5	57						
MRS-MRT 110	35	40	598	1.2	57						
MRS-MRT 110	29	49	712	0.9	57						
MRS 130	29	49	722	1.3	71						
MRS 130	25	56	814	1.2	71						
MRS 150	20	70	974	1.3	101						
MRA 100/130	20	70	1074	1.3	85						
MRS 150	18	80	1064	1.1	101						
MRA 100/130	18	80	1277	1.0	85						
MRS 150	14	100	1289	0.9	101						
MRA 100/130	14	98	1344	1.1	85						
MRA 100/130	12	120	1793	1.0	85						
MRA 100/150	10	140	1891	1.1	101						
MRA 100/150	8.9	160	2357	1.1	101						
4.0 kW											
	min ⁻¹	i =	Nm	SF	kg						
MRS-MRT 85	280	5	122	2.3	43						
MRS-MRT 85	200	7	168	1.5	43						
MRS-MRT 85	140	10	235	1.1	43						
MRS-MRT 110	93	15	344	1.6	65						
MRS-MRT 110	70	20	453	1.4	65						
MRS-MRT 110	50	28	581	1.1	65						
MRS 130	35	40	829	1.4	79						
MRS 130	29	49	963	1.0	79						
MRS 130	25	56	1085	0.9	79						

Reductores Serie RS y RT

Motores eléctricos

Dimensiones

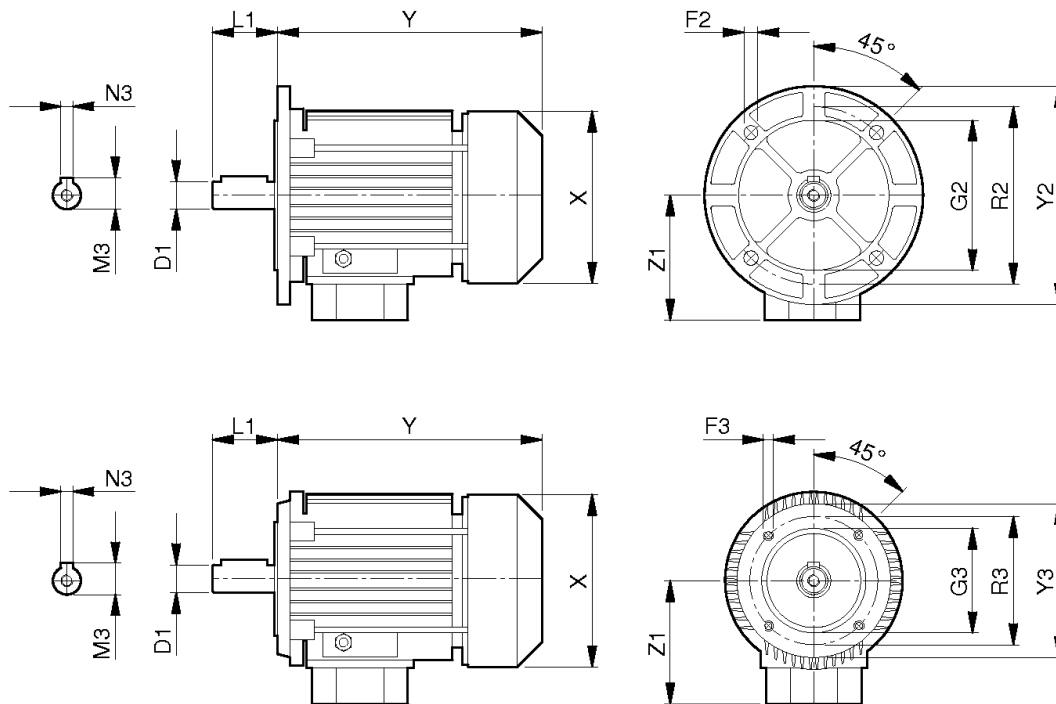

MOTOR IEC	56	63	71	80	90 S / L	100 / 112	132 S / M	160 M / L
D _{1(j6)} x L ₁	9 x 20	11 x 23	14 x 30	19 x 40	24 x 50	28 x 60	38 x 80	42 x 110
F ₂	7	9	9	11	11	14	14	18
F ₃	M.5	M.5	M.6	M.6	M.8	M.8	M.10	12
G _{2(j6)}	80	95	110	130	130	180	230	250
G _{3(j6)}	50	60	70	80	95	110	130	180
M ₃	10.4	12.8	16.3	21.8	27.3	31.3	41.3	45.3
N ₃	3	4	5	6	8	8	8	8
R ₂	100	115	130	165	165	215	265	300
R ₃	65	75	85	100	115	130	165	215
X	110	123	140	159	176	195 / 219	258	315
Y	168	185	215	238	255 / 280	309 / 328	368 / 405	478 / 522
Y ₂	120	140	160	200	200	250	300	350
Y ₃	80	90	105	120	140	160	200	250
Z ₁	108	110	121	138	149	160 / 172	192	220
Peso kg	2,5	4,5	6,0	10,0	13,5	21 / 29	43 / 52	68 / 78

Dimensiones sin compromiso

Reductores Serie RS y RT

Dimensiones

Tornillo sin fin RS

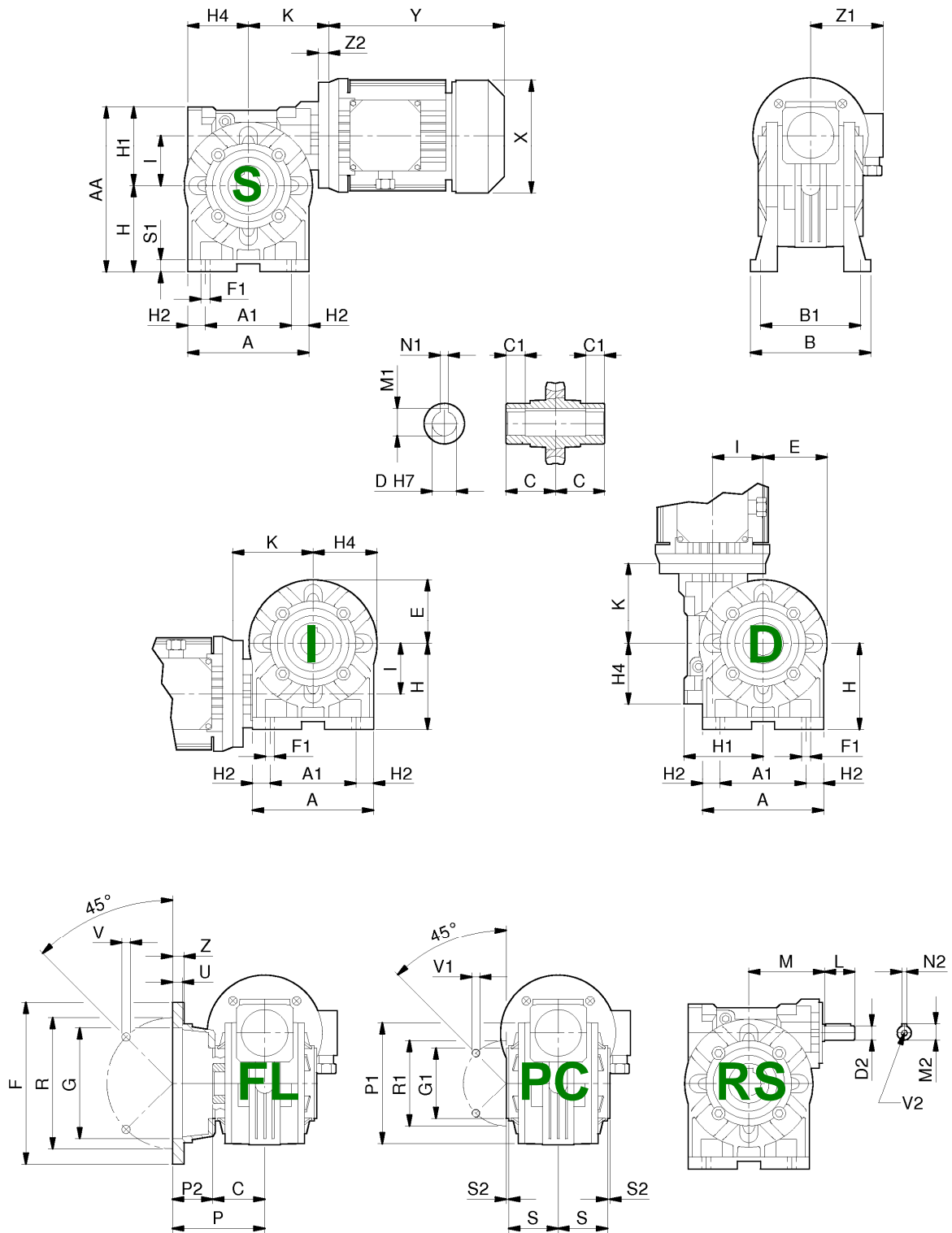

Reductores Serie RS y RT

Tornillo sin fin RS

Dimensiones

RS	28	40	50	60	70	85	110	130	150
A ₁	52	70	85	95	120	140	200	235	260
AA	99	138	163	192	221	252	342	400	454
B	78	102	119	136	140	168	200	230	250
B ₁	66	84	99	111	116	140	162	190	210
C	30	41	49	60	60	61	77,5	90	105
C ₁	26,5	26	30,5	39	37,5	38,5	52,5	85	100
D _(H7)	14	19	24	25	28	32	42	48	55
D* _(H7)	---	18	25	---	30	35	---	---	---
D _{2 (H6)}	9	11	14	19	19	24	28	38	42
E	34	50	61	70	80	98	125	143	168
F	70	140	160	180	200	200	250	300	350
F ₁	5,5	7	9	11	11	13	14	15	19
G _(H8)	40	95	110	115	130	130	180	230	250
G _{1 (F8)}	42	60	70	70	80	110	130	180	180
H	52	71	85	100	115	135	172	200	230
H ₁	47	67	78	92	106	117	170	200	224
H ₂	9	15	17,5	21,5	19	26,5	25	25,5	38
H ₄	40	50	60	72	86	103	142	159	183
I	28	40	50	60	70	85	110	130	150
K	57,5	70,5	83-88*	93-94*	117-118*	134-137*	151-153*	165-166*	191-211*
L	20	23	30	40	40	40	60	80	100
M	50	65	75	87	110	123,5	146	166	195
M ₁	16,3	21,8	27,3	28,3	31,3	35,3	45,3	51,8	59,3
M ₂	10,2	12,5	16	22,5	22,5	27	31	41	45
N ₁	5	6	8	8	8	10	12	14	16
N ₂	3	4	5	6	6	8	8	10	12
P	49	82	91,5	116	111	100	150	150	160
P ₁	67	94	100	102	118	150	200	234	250
P ₂	19	41	42,5	56	51	39	72,5	60	55
R	56	115	130	150	165	165	215	265	300
R ₁	56	83	85	85	100	130	165	215	215
S	32	38	49	57,5	57	56,5	74,5	87	102
S ₁	6	9	12	12	14	15	17	19	20
S ₂	-3	2	2,5	2,5	3	3	2,5	5	5
U	4	6	10	10	12	6	5	5	6
V	6,5 (4)	9 (4)	9 (4)	11 (4)	13 (4)	13 (4)	15 (8)	15 (8)	19 (8)
V ₁	M6x6 (4)	M6x9 (4)	M8x12 (4)	M8x15 (8)	M8x18 (8)	M10x20 (8)	M12x21 (4)	M12x24 (4)	M14x30 (8)
V ₂	M4x10	M4x10	M6x15	M8x20	M8x20	M8x20	M8x20	M10x22	M12x25
Z	6	10	10	11	14	14	16	18	20

D* - Hueco sobre demanda

V₁ - 90° para RS28

(*) - IEC71-B14 (FRS50) – IEC71-B14 (FRS60) – IEC 80-B14 (FRS70) – IEC 90-B14 (FRS85)

(*) - IEC100/112-B14 (FRS110) – IEC 100/112-B5 (FRS130) – IEC 160-B5 (FRS150)

Dimensiones motores: ver página 25

Dimensiones sin compromiso

Reductores Serie RS y RT

Dimensiones

Tornillo sin fin y engranajes RA

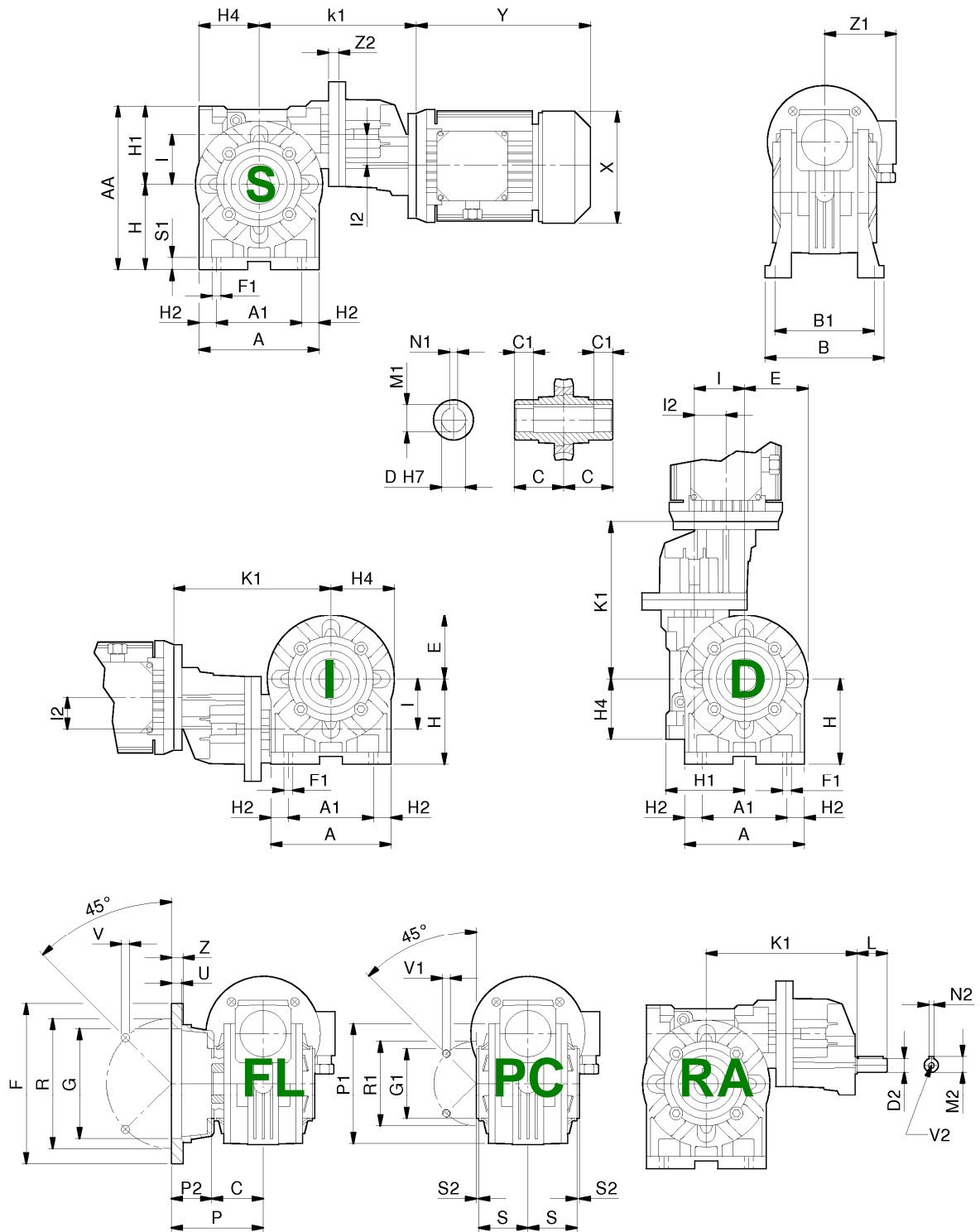

Reductores Serie RS y RT

Tornillo sin fin y engranajes RA

Dimensiones

RA	63/40	63/50	63/60	71/50	71/60	71/70	71/85	80/60	80/70	80/85	80/110	100/110	100/130	100/150
A ₁	70	85	95	85	95	120	140	95	120	140	200	250	235	260
AA	138	163	192	163	192	221	252	192	221	252	342	200	400	454
B	102	119	136	119	136	140	168	136	140	168	200	333	230	250
B ₁	84	99	111	99	111	116	140	111	116	140	162	200	190	210
C	41	49	60	49	60	60	61	60	60	61	77,5	162	90	105
C ₁	26	30,5	39	30,5	39	37,5	38,5	39	37,5	38,5	52,5	52,5	85	
D	19	24	25	24	25	28	32	25	28	32	42	77,5	48	55
D*	18	25	---	25	---	30	35	---	30	35	---	42	---	---
D ₂	11	11	11	14	14	14	14	19	19	19	19	---	19	19
E	50	61	70	61	70	80	98	70	80	98	125	24	143	168
F	140	160	180	160	180	200	200	180	200	200	250	125	300	350
F ₁	7	9	11	9	11	11	13	11	11	13	14	250	15	19
G	95	110	115	110	115	130	130	115	130	130	180	14	230	250
G ₁	60	70	70	70	70	80	110	70	80	110	130	180	180	180
H	71	85	100	85	100	115	135	100	115	135	172	130	200	230
H ₁	67	78	92	78	92	106	117	92	106	117	170	172	200	224
H ₂	15	17,5	21,5	17,5	21,5	19	26,5	21,5	19	26,5	25	161	25,5	38
H ₄	50	60	72	60	72	86	103	72	86	103	142	25	159	189
I	40	50	60	50	60	70	85	60	70	85	110	139	130	150
I ₁	32	32	32	40	40	40	40	50	50	50	50	110	75	75
K	153,	171	177	173	183	209	224	207	232,	250,	264,	63	290	316
				178*	188*	214*	229*					328	300*	326*
L	23	23	23	30	30	30	30	40	40	40	40	50	40	40
M ₁	21,8	27,3	28,3	27,3	28,3	31,3	35,3	28,3	31,3	35,3	45,3	45,3	51,8	59,3
M ₂	12,5	12,5	12,5	16	16	16	16	22,5	22,5	22,5	22,5	27	22,5	22,5
N ₁	6	8	8	8	8	8	10	8	8	10	12	12	14	16
N ₂	4	4	4	5	5	5	5	6	6	6	6	8	6	6
P	82	91,5	116	91,5	116	111	100	116	111	100	150	150	150	160
P ₁	94	100	102	100	102	118	150	102	118	150	200	200	234	250
P ₂	41	42,5	56	42,5	56	51	39	56	51	39	72,5	72,5	60	55
R	115	130	150	130	150	165	165	150	165	165	215	215	265	300
R ₁	83	85	85	85	85	100	130	85	100	130	165	165	215	215
S	38	49	57,5	49	57,5	57	56,5	57,5	57	56,5	74,5	74,5	87	102
S ₁	9	12	12	12	12	14	15	12	14	15	17	17	19	20
S ₂	2	2,5	2,5	2,5	2,5	3	3	2,5	3	3	2,5	2,5	5	5
U	6	10	10	10	10	12	6	10	12	6	5	5	5	6
V	9 (4)	9 (4)	11 (4)	9 (4)	11 (4)	13 (4)	13 (4)	11 (4)	13 (4)	13 (4)	15 (8)	15 (8)	15 (8)	19 (8)
V ₁	M6x9 (4)	M8x12 (4)	M8x15 (8)	M8x12 (4)	M8x15 (8)	M8x18 (8)	M10x2 (8)	M8x15 (8)	M8x18 (8)	M10x2 (8)	M12x2 (8)	M12x2 (8)	M12x2 (8)	M14x3 (8)
V ₂	M4x10	M4x10	M4x10	M6x15	M6x15	M6x15	M6x15	M8x20	M8x20	M8x20	M8x20	M8x20	M8x20	M8x20
Y ₁	105	105	105	120	120	120	120	140	140	140	140	140	200	200
Z	10	10	11	10	11	14	14	11	14	14	16	16	18	20

D* - Hueco sobre demanda

V₁ - 90° para RS28

(*) - IEC71-B14 (FRA 71/....) - IEC100-B5 (FRA130) - IEC100-B5 (FRA150)

Dimensiones motores: ver página 25

Dimensiones sin compromiso

Reductores Serie RS y RT

Dimensiones

Reductores de doble tornillo sin fin RS/RS

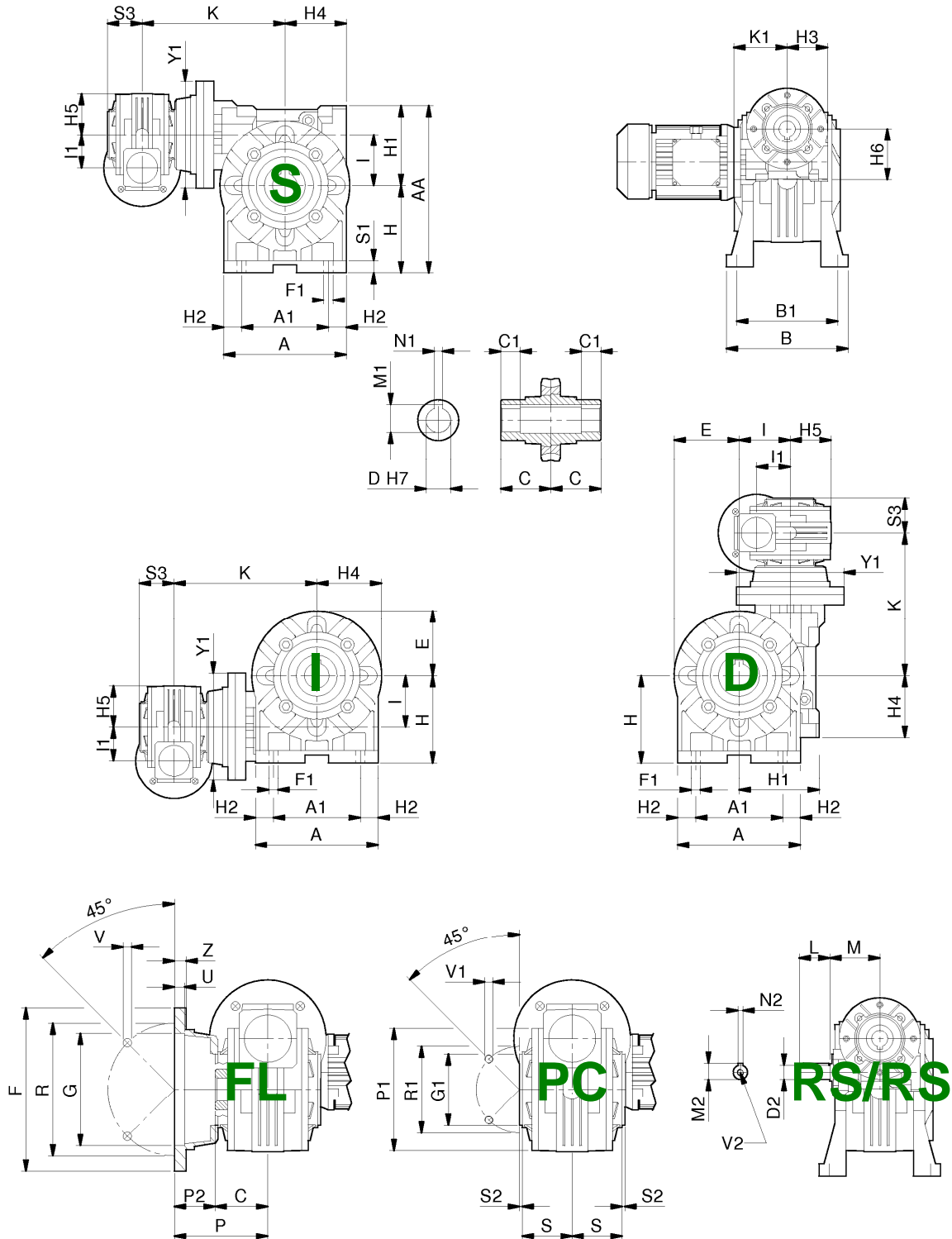

Reductores Serie RS y RT

Reductores de doble tornillo sin fin RS/RS

Dimensiones

RS/RS	28/28	28/40	28/50	28/60	40/70	40/85	50/110	60/130	70/150
A ₁	52	70	85	95	120	140	200	235	260
AA	99	138	163	192	221	252	342	400	454
B	78	102	119	136	140	168	200	230	250
B ₁	66	84	99	111	116	140	162	190	210
C	30	41	49	60	60	61	77,5	90	105
C ₁	26,5	26	30,5	39	37,5	38,5	52,5	85	100
D ^(H7)	14	19	24	25	28	32	42	48	55
D* ^(H7)	---	18	25	---	30	35	---	---	---
D ₂ ^(h6)	9	9	9	9	11	11	14	38	42
E	34	50	61	70	80	98	125	143	168
F	70	140	160	180	200	200	250	300	350
F ₁	5,5	7	9	11	11	13	14	15	19
G ^(H8)	40	95	110	115	130	130	180	230	250
G ₁ ^(f8)	42	60	70	70	80	110	130	180	180
H	52	71	85	100	115	135	172	200	230
H ₁	47	67	78	92	106	117	170	200	224
H ₂	9	15	17,5	21,5	19	26,5	25	25,5	38
H ₃	40	40	40	40	50	50	60	72	86
H ₄	40	50	60	72	86	103	142	159	189
H ₅	34	34	34	34	50	50	61	70	80
H ₆	47	47	47	47	67	67	78	92	106
I	28	40	50	60	70	85	110	130	150
I ₂	28	28	28	28	40	40	50	60	70
K	99,5	123	138,5	146	182	199	246	246	300
K ₁	57,5	57,5	57,5	57,5	70,5	70,5	83 - 88*	93 - 94*	117 - 118*
L	20	20	20	20	23	23	30	40	40
M	50	50	50	50	65	65	75	87	110
M ₁	16,3	21,8	27,3	28,3	31,3	35,3	45,3	51,8	59,3
M ₂	10,2	10,2	10,2	10,2	12,5	12,5	16	22,5	22,5
N ₁	5	6	8	8	8	10	12	14	16
N ₂	3	3	3	3	4	4	5	6	6
P	49	82	91,5	116	111	100	150	150	160
P ₁	67	94	100	102	118	150	200	234	250
P ₂	19	41	42,5	56	51	39	72,5	60	55
R	56	115	130	150	165	165	215	265	300
R ₁	56	83	85	85	100	130	165	215	215
S	32	38	49	57,5	57	56,5	74,5	87	102
S ₁	6	9	12	12	14	15	17	19	20
S ₂	-3	2	2,5	2,5	3	3	2,5	5	5
S ₃	30	30	30	30	41	41	49	60	60
U	4	6	10	10	12	6	5	5	6
V	6,5 (4)	9 (4)	9 (4)	11 (4)	13 (4)	13 (4)	15 (8)	15 (8)	19 (8)
V ₁	M6x6 (4)	M6x9 (4)	M8x12 (4)	M8x15 (8)	M8x18 (8)	M10x20 (8)	M12x21 (4)	M12x24 (4)	M14x30 (4)
V ₂	M4x10	M4x10	M4x10	M4x10	M4x10	M4x10	M6x15	M8x20	M8x20
Y ₁	80	80	80	90	115	115	110	180	200
Z	6	10	10	11	14	14	16	18	20

D* - Hueco sobre demanda

V₁ - 90° para RS28

(*) - IEC71-B14 (FRS50) - IEC71-B14 (FRS60) - IEC 80-B14 (FRS70)

Dimensiones motores: ver página 25

Dimensiones sin compromiso

Reductores Serie RS y RT

Dimensiones

Variantes constructivas RS

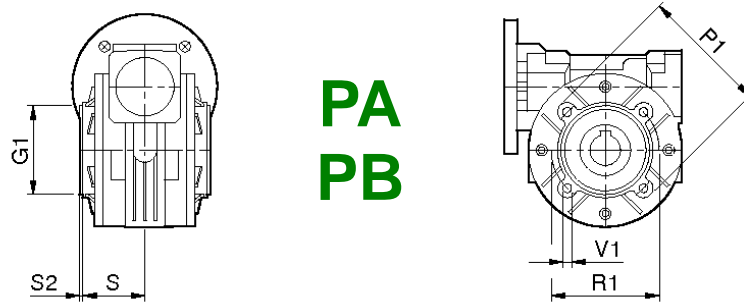
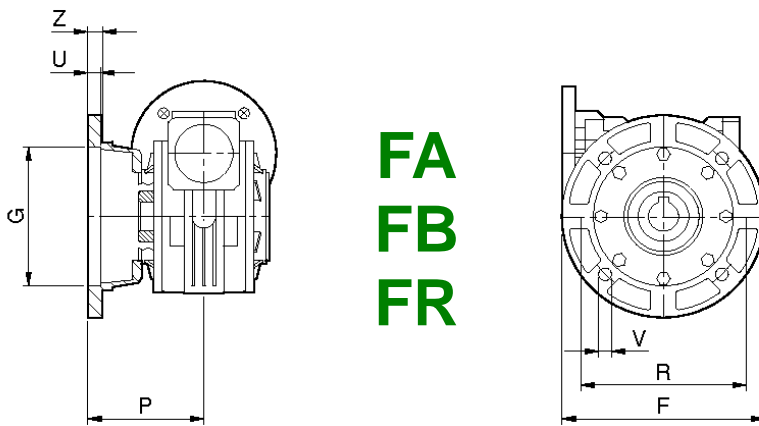
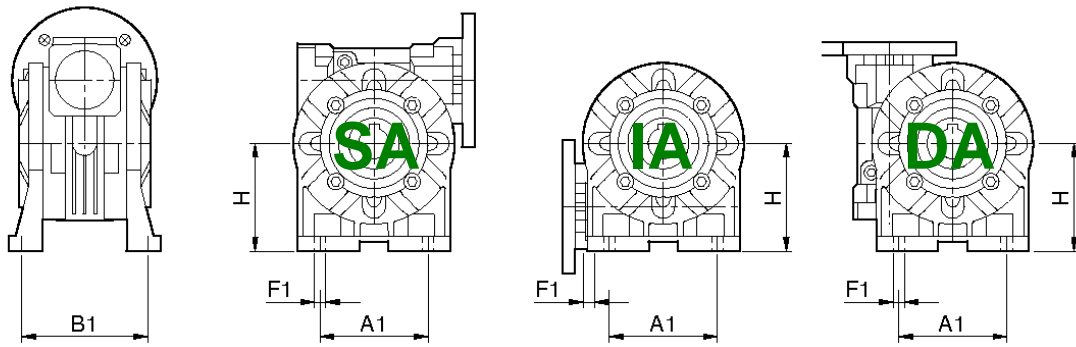

Reductores Serie RS y RT

Variantes constructivas RS

Dimensiones

RS	28	40	50	60	70	85	110	130	150
SA-IA-DA									
A ₁	---	52	63	---	---	140	---	---	---
B ₁	---	81	98.5	---	---	146	---	---	---
F ₁	---	8.5	9	---	---	11	---	---	---
H	---	72	82	---	---	142	---	---	---
FA									
F	80	114	125	165	165	---	---	---	---
G _(H8)	50	60	70	110	115	---	---	---	---
P	50.5	69	93	90	116	---	---	---	---
R	68	87	90	130	150	---	---	---	---
U	3.5	5	5	10	4.5	---	---	---	---
V	6.5 (4)	9 (4)	11 (4)	10.5 (4)	11 (4)	---	---	---	---
Z	7	8	10	15	10	---	---	---	---
FB									
F	---	120	---	180	---	210	270	---	---
G _(H8)	---	80	---	115	---	152	170	---	---
P	---	62	---	86	---	119.5	131.5	---	---
R	---	100	---	150	---	176	230	---	---
U	---	4	---	3.5	---	5	5	---	---
V	---	9 (4)	---	11 (4)	---	11 (4)	13 (4)	---	---
Z	---	9	---	12	---	14	18	---	---
FR									
F	---	---	---	---	160	---	---	---	---
G _(H8)	---	---	---	---	110	---	---	---	---
P	---	---	---	---	84.5	---	---	---	---
R	---	---	---	---	130	---	---	---	---
U	---	---	---	---	4.5	---	---	---	---
V	---	---	---	---	11 (4)	---	---	---	---
Z	---	---	---	---	14	---	---	---	---
PA									
G _{1 (H8)}	---	50	68	75	90	---	---	---	---
P ₁	---	95	110	104	125	---	---	---	---
R ₁	---	65	94	90	110	---	---	---	---
S	---	38	49	47.5	55	---	---	---	---
S ₂	---	2	2.5	5.5	3	---	---	---	---
V ₁	---	M6x8 (4)	M6x12.5(4)	M8x14 (4)	M8x14 (4)	---	---	---	---
PB									
G _{1 (H8)}	---	---	60	---	70	---	---	---	---
P ₁	---	---	110	---	116	---	---	---	---
R ₁	---	---	75	---	85	---	---	---	---
S	---	---	49	---	67	---	---	---	---
S ₂	---	---	2.5	---	4	---	---	---	---
V ₁	---	---	M6x12.5(4)	---	M8x14 (4)	---	---	---	---

Dimensiones sin compromiso

Reductores Serie RS y RT

Dimensiones

Accesorios RS

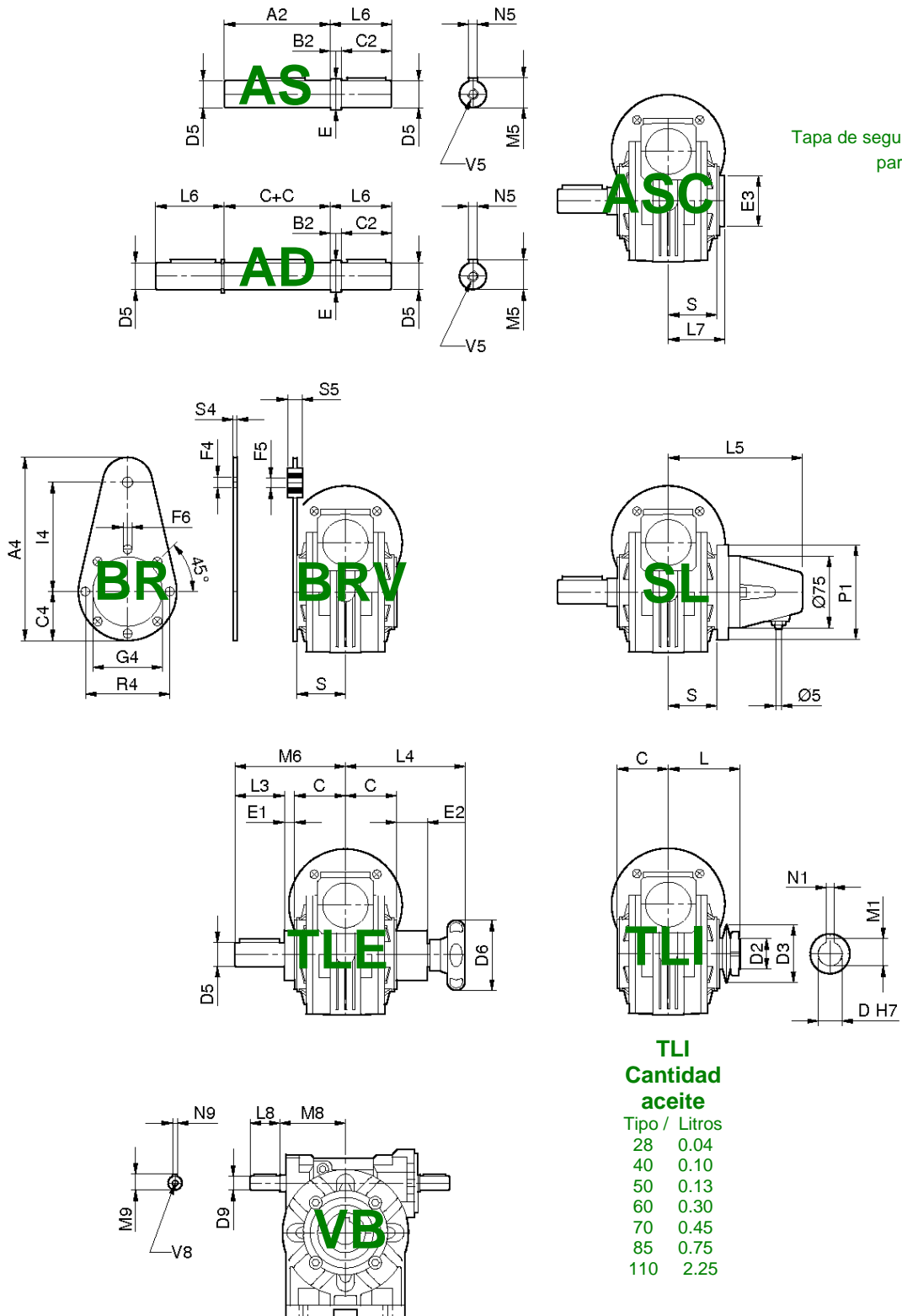

Reductores Serie RS y RT

Accesorios RS

Dimensiones

RS		28	40	50	60	70	85	110	130	150
AS & AD	A ₂	58	80	95	117	117	119	153	177	207
	B ₂	1	10	10	10	10	10	10	20	20
	C	30	41	49	60	60	61	77.5	90	105
	C ₂	30	40	45	50	60	70	100	110	110
	D ₅ (g6)	14	19 (18)	24 (25)	25	28	32 (35)	42	48	55
	E	14	22	28	30	34	38	50	58	63
	L ₆	31	50	55	60	70	80	106	130	130
	M ₅	16	21.5	27	28	31	35	45	51.5	59
	N ₅	5	6	8	8	8	10	12	14	16
	V ₅	M5x10	M8x20	M8x20	M8x20	M8x20	M10x25	M10x25	---	---
ASC	E ₃	42	55	62	62	72	90	120	---	---
	L ₇	36	48.5	55.5	68.5	67	77	85	---	---
	S	27.5	38.5	46.5	57	57	67	74	---	---
BR BRV	A ₄	138	168	185	235	295	313	388	---	---
	C ₄	38	43	60	55	65	75	100	---	---
	F ₄	10.5	10.5	10.5	10.5	10.5	20.5	20.5	---	---
	F ₅	10	10	10	10	10	20	20	---	---
	F ₆	7	7	9	9	9	12	13	---	---
	G ₄	55	60	70	80	95	110	130	---	---
	I ₄	80	100	100	150	150	200	250	---	---
	R ₄	65	75	85	95	115	130	165	---	---
	S ₄	4	4	4	6	6	6	6	---	---
	S ₅	15	15	15	20	20	25	25	---	---
SL	L ₅	100	110	120	130	130	140	155	---	---
	P ₁	77	88	100	110	132	160	200	---	---
	S	27.5	38.5	46.5	57	57	67	74	---	---
TLE	D ₆	52	70	70	70	80	100	100	---	---
	E ₁	10	12	12	15	14	19	24	---	---
	E ₂	28	37	31	40	46	57	71	---	---
	L ₃	30	40	50	50	60	70	80	---	---
	L ₄	94	116	118	128	146	168	201	---	---
	M ₆	70	93	111	125	134	150	181	---	---
TLI	D (H7)	14	19	24	25	28	32	42	---	---
	D ₂	40	56	71	71	80	90	125	---	---
	D ₃	14.2 x 20	19.5 x 20.5	24.5 x 28	25.5 x 26	28.5 x 22	32.5 x 27	42.5 x 38.5	---	---
	L	45	61.5	77	86.5	89	94	109	---	---
	M ₁	15.4*	21.8	27.3	27.3*	31.3	35.3	45.3	---	---
	N ₁ (H9)	5	6	8	8	8	10	12	---	---
VB	D ₉	9	11	14	19	19	24	28	---	---
	L ₈	20	23	30	40	40	50	60	---	---
	M ₈	43	55	65	77	84	106.5	145	---	---
	M ₉	10.2	12.5	16	22.5	22.5	27	31	---	---
	N ₉	3	4	5	6	6	8	8	---	---
	V ₈	M4x10	M4x10	M6x15	M8x20	M8x20	M8x20	M8x20	---	---

* = Chaveta rebajada

- D₅ (..) = Diámetro sobre demanda

Reductores Serie RS y RT

Dimensiones

Tornillo sin fin RT

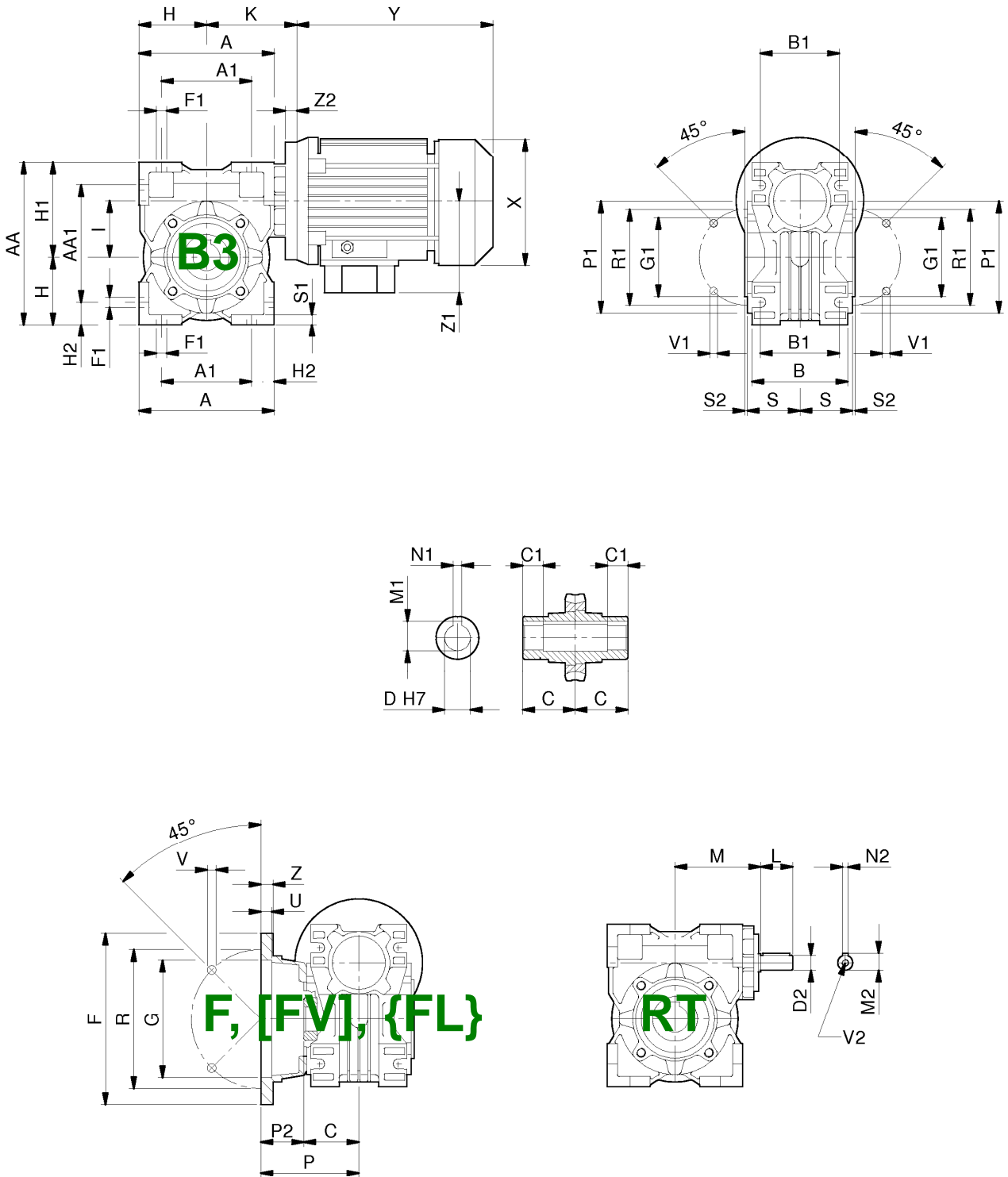

Reductores Serie RS y RT

Tornillo sin fin RT

Dimensiones

RT	28	40	50	60	70	85	110
A	80	100	120	144	172	206	255
A ₁	54	70	80	100	120	140	170
AA	97	121,5	144	174	205	238	295
AA ₁	71	91,5	104	130	153	172	210
B	53	71	85	100	112	130	144
B ₁	44	60	70	85	90	100	115
C	14	41	49	60	60	61	77,5
C ₁	26,5	26	30,5	39	37,5	38,5	52,5
D _(H7)	14	19	24	25	28	32	42
D* _(H7)	---	18	25	---	30	35	---
D _{2 (h6)}	9	11	14	19	19	24	28
F	80	110 {110}	125 [160] 125}	180 {180}	200	210	270
F ₁	7	7	9	9	11	13	15
G _(H8)	50	60 {60}	70 [110] {70}	115 {115}	130	152	170
G _{1 (h8)}	55	60	70	80	95	110	130
H	40	50	60	72	86	103	127,5
H ₁	57	71,5	84	102	119	135	167,5
H ₂	13	15	20	22	26	33	42,5
I	28	40	50	60	70	85	110
K	57,5	70,5	83-88*	93-94*	117-118*	134-137*	151-153*
L	20	23	30	40	40	50	60
M	50	65	75	87	110	123,5	146
M ₁	16,3	21,8	27,3	28,3	31,3	35,3	45,3
M ₂	10,2	12,5	16	22,5	22,5	27	31
N ₁	5	6	8	8	8	10	12
N ₂	3	4	5	6	6	8	8
P	53	69 {99}	93 [90,5] {123}	86 {116}	111	111	131
P ₁	75	86	100	110	130	160	200
P ₂	23	28 {58}	44 [41,5] {74}	25 {56}	51	50	53,5
R	68	87 {87}	90 [130] {90}	150,5 {150,5}	165	175	230
R ₁	65	75	85	95	115	130	165
S	27,5	38,5	46,5	57	57	67	74
S ₁	6	7	8	10	11	14	13
S ₂	2,5	2,5	3	3	3	3	3,5
U	10	4 {4}	5 [11] {5}	6,5 {6,5}	12	6	5
V	7	9 {9}	10,5 [9] {9}	11 {11}	13	13	14
V ₁	M6x10 (4)	M6x8,5 (4)	M8x10 (4)	M8x16 (8)	M8x16 (8)	M10x18 (8)	M10x21 (8)
V ₂	M4x10	M4x10	M6x15	M8x20	M8x20	M8x20	M8x20
Z	7	6 {8}	10 [13] {10}	10 {10}	14	16	18
Z ₂	13	13	13 - 18,5	14 - 15	15,5 - 17,5	15,5 - 18,5	18-20

D* - Hueco sobre demanda

V₁ - 90° para RT28

(*) - IEC71-B14 (**FRS50**) - IEC71-B14 (**FRS60**) - IEC 80-B14 (**FRS70**) - IEC 90-B14 (**FRS85**) - IEC100/112-B14 (**FRS110**)

Dimensiones motores: ver página 25

Dimensiones sin compromiso

Reductores Serie RS y RT

Dimensiones

Tornillo sin fin y engranajes TA

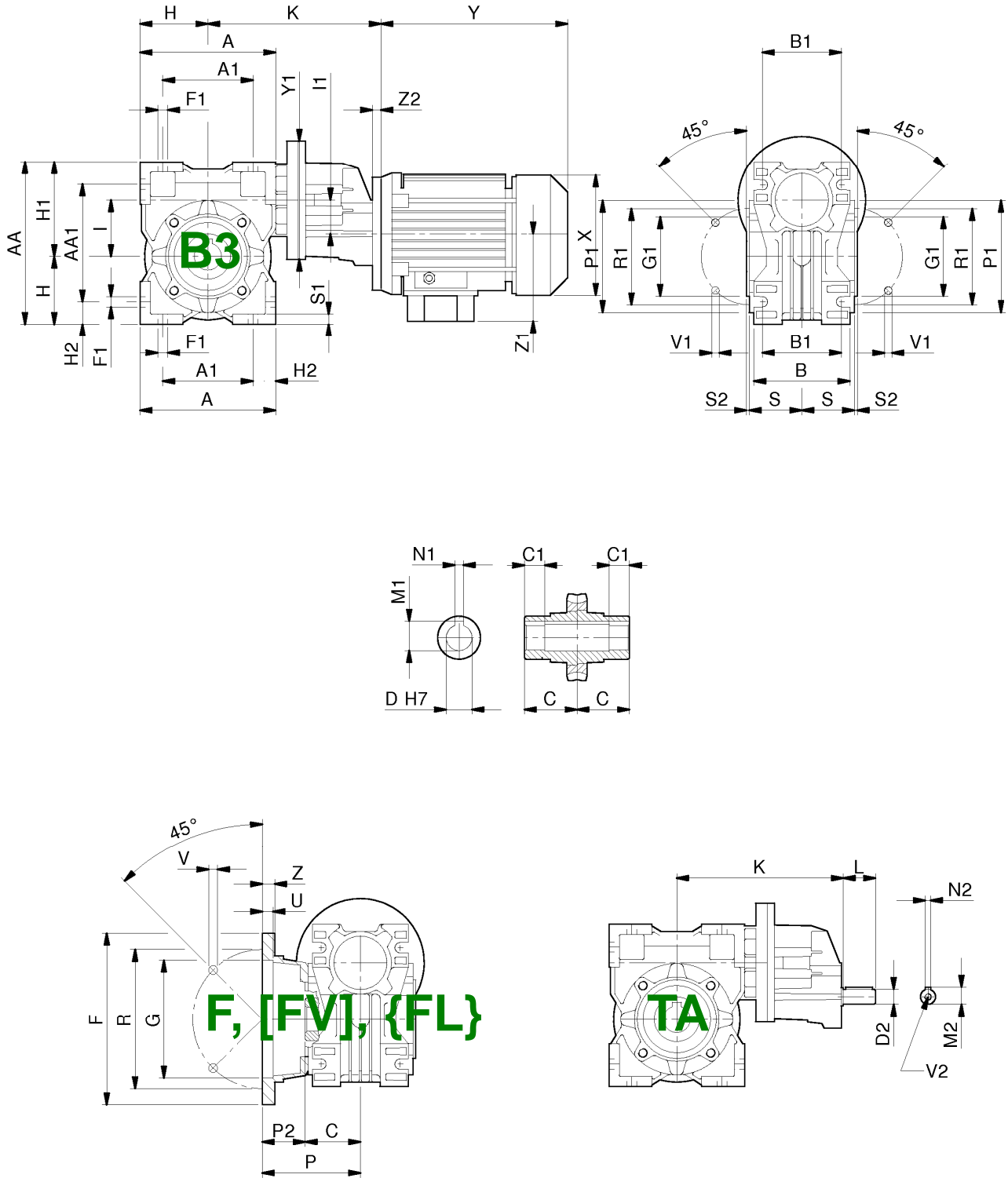

Reductores Serie RS y RT

Tornillo sin fin y engranajes TA

Dimensiones

TA	63/40	63/50	63/60	71/50	71/60	71/70	71/85	80/60	80/70	80/85	80/110	100/110
A	100	120	144	120	144	172	206	144	172	206	255	255
A ₁	70	80	100	80	100	120	140	100	120	140	170	170
AA	121,5	144	174	144	174	205	238	174	205	238	295	295
AA ₁	91,5	104	130	104	130	153	172	130	153	172	210	210
B	71	85	100	85	100	112	130	100	112	130	144	144
B ₁	60	70	85	70	85	90	100	85	90	100	115	115
C	41	49	60	49	60	60	61	60	60	61	77,5	77,5
C ₁	26	30,5	39	30,5	39	37,5	38,5	39	37,5	38,5	52,5	52,5
D ^(H7)	19	24	25	24	25	28	32	25	28	32	42	42
D*	18	25	---	25	---	30	35	---	30	35	---	---
D ₄ ^(h6)	11	11	11	14	14	14	14	19	19	19	19	24
F	110	125	180	125	180	200	210	180	200	210	270	270
F ₁	7	9	9	9	9	11	13	9	11	13	15	15
G ^(H8)	60 {60}	70 [110]	115	70 [110]	115	130	152	115	130	152	170	170
G ₁ ^(h8)	60	70	80	70	80	95	110	80	95	110	130	130
H	50	60	72	60	72	86	103	72	86	103	127,5	127,5
H ₁	71,5	84	102	84	102	119	135	102	119	135	167,5	167,5
H ₂	15	20	22	20	22	26	33	22	26	33	42,5	42,5
I	40	50	60	50	60	70	85	60	70	85	110	110
I ₁	32	32	32	40	40	40	40	50	50	50	50	50
K	153,5	171	177	173-	183	209-	224	207	232,5	250,5	264,5	328
L	23	23	23	30	30	30	30	40	40	40	40	50
M ₁	21,8	27,3	28,3	27,3	28,3	31,3	35,3	28,3	31,3	35,3	45,3	45,3
M ₂	12,5	12,5	12,5	16	16	16	16	22,5	22,5	22,5	22,5	27
N ₁	6	8	8	8	8	8	10	8	8	10	12	12
N ₄	4	4	4	5	5	5	5	6	6	6	6	8
P	69 {99}	93	86 {116}	93	86 {116}	111	111	86 {116}	111	111	131	131
P ₁	86	100	110	100	110	130	160	110	130	160	200	200
P ₂	28 {58}	44	25 {56}	44	25 {56}	51	50	25 {56}	51	50	53,5	53,5
R	87	90	150,5	90 [130]	150,5	165	175	150,5	165	175	230	230
R ₁	75	85	95	85	95	115	130	95	115	130	165	165
S	38,5	46,5	57	46,5	57	57	67	57	57	67	74	74
S ₁	7	8	10	8	10	11	14	10	11	14	13	13
S ₂	2,5	3	3	3	3	3	3	3	3	3	3,5	3,5
U	4 {4}	5 [11] {5}	6,5 {6,5}	5 [11] {5}	6,5 {6,5}	12	6	6,5 {6,5}	12	6	5	5
V	9 {9}	10,5 [9]	11	10,5 [9]	11	13	13	11	13	13	14	14
V ₁	M6x8 (4)	M8x10 (4)	M8x16 (8)	M8x10 (4)	M8x16 (8)	M8x16 (8)	M10x18	M8x16 (8)	M8x16 (8)	M10x18 (8)	M10x21 (8)	M10x21 (8)
V ₃	M4 x 10	M4 x 10	M4 x 10	M6 x 15	M6 x 15	M6 x 15	M6 x 15	M8 x 20	M8 x 20	M8 x 20	M8 x 20	M8 x 20
Y ₁	105	105	105	120	120	120	120	140	140	140	140	140
Z	6 {8}	10 [13] {10}	10 {10}	10 [13] {10}	10 {10}	14	16	10 {10}	14	16	18	18
Z ₂	13	13	13	13 -	13 -	13 -	13 -	14 -	14 -	14 -	14 -	14 - 15

D* - Hueco sobre demanda

V₁ - 90° para RT28

(*) - IEC71-B14 (FTA 71/....)

Dimensiones motores: ver página 25

Dimensiones sin compromiso

Reductores Serie RS y RT

Dimensiones

Reductores de doble tornillo sin fin RT/RT

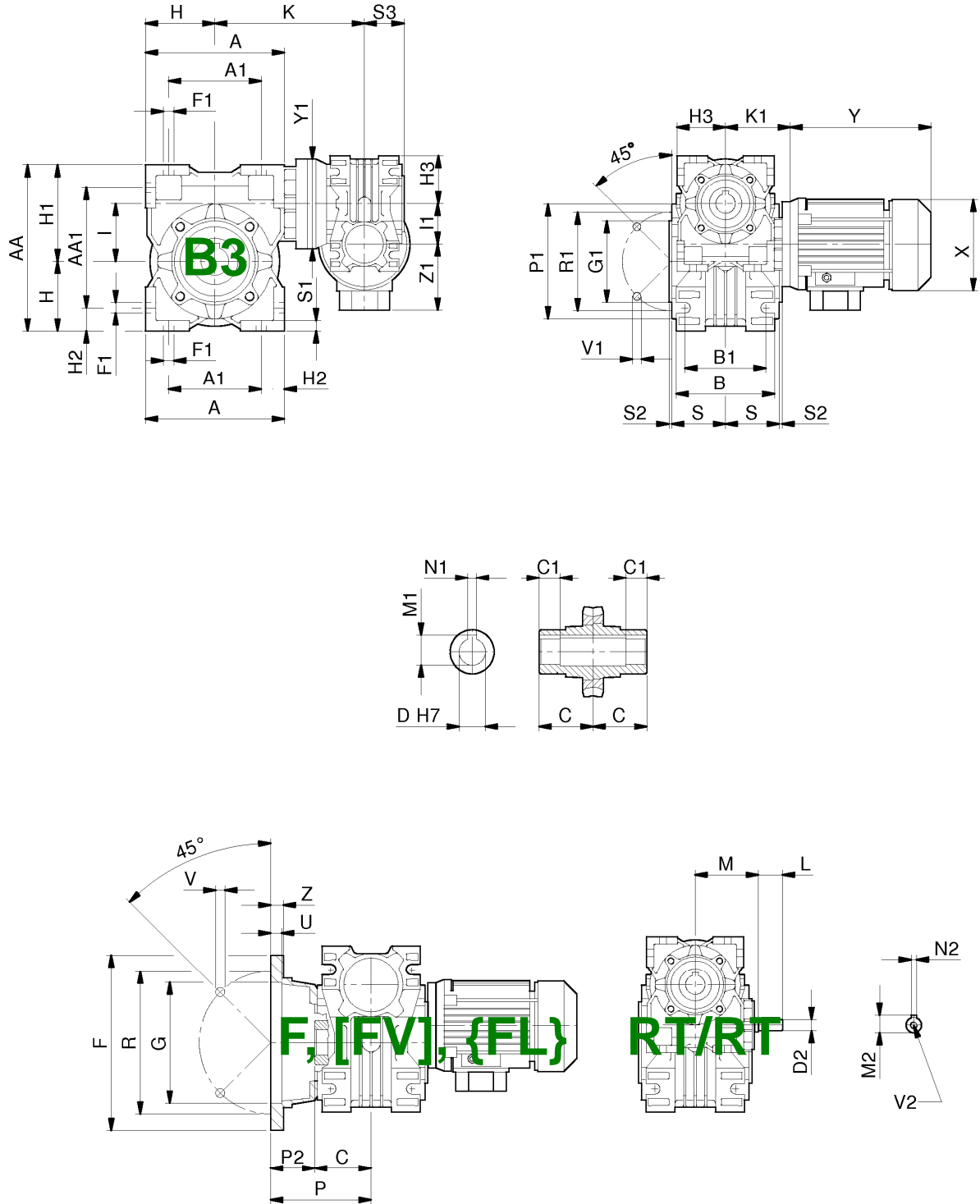

Reductores Serie RS y RT

Reductores de doble tornillo sin fin RT/RT

Dimensiones

RT/RT	28/28	28/40	28/50	28/60	40/70	40/85	50/110
A	80	100	120	144	172	206	255
A ₁	54	70	80	100	120	140	170
AA	97	121,5	144	174	205	238	295
AA ₁	71	91,5	104	130	153	172	210
B	53	71	85	100	112	130	144
B ₁	44	60	70	85	90	100	115
C	30	41	49	60	60	61	77,5
C ₁	26,5	26	30,5	39	37,5	38,5	52,5
D (H7)	14	19	24	25	28	32	42
D* (H7)	---	18	25	---	30	35	---
D ₂ (h6)	9	9	9	9	11	11	14
F	80	110 {110}	125 [160] {125}	180 {180}	200	210	270
F ₁	7	7	9	9	11	13	15
G (H8)	50	60 {60}	70 [110] {70}	115 {115}	130	152	170
G ₁ (h8)	55	60	70	80	95	110	130
H	40	50	60	72	86	103	127,5
H ₁	57	71,5	84	102	119	135	167,5
H ₂	13	15	20	22	26	33	42,5
H ₃	40	40	40	40	50	50	60
I	28	40	50	60	70	85	110
I ₁	28	28	28	28	40	40	50
K	79,5	118,5	129	145,5	143,5	199	203
K ₁	57,5	57,5	57,5	57,5	70,5	70,5	83 - 88*
L	20	20	20	20	23	23	30
M	50	50	50	50	65	65	75
M ₁	16,3	21,8	27,3	28,3	31,3	35,3	45,3
M ₂	10,2	10,2	10,2	10,2	12,5	12,5	16
N ₁	5	6	8	8	8	10	12
N ₂	3	3	3	3	4	4	5
P	53	69 {99}	93 [90,5] {123}	86 {116}	111	111	131
P ₁	75	86	100	110	130	160	200
P ₂	23	28 {58}	44 [41,5] {74}	25 {56}	51	50	53,5
R	68	87 {87}	90 [130] {90}	150,5 {150,5}	165	175	230
R ₁	65	75	85	95	115	130	165
S	27,5	38,5	46,5	57	57	67	74
S ₁	6	7	8	10	11	14	13
S ₂	2,5	2,5	3	3	3	3	3,5
S ₃	30	30	30	30	41	41	49
U	10	4 {4}	5 [11] {5}	6,5 {6,5}	12	6	5
V	7	9 {9}	10,5 [9] {9}	11 {11}	13	13	14
V ₁	M6x10 (4)	M6x8,5 (4)	M8x10 (4)	M8x16 (8)	M8x16 (8)	M10x18 (8)	M10x21 (8)
V ₂	M4x10	M4x10	M4x10	M4x10	M4x10	M4x10	M6x15
Y ₁	80	90	90	90	120	120	120
Z	7	6 {8}	10 [13] {10}	10 {10}	14	16	18

D* - Hueco sobre demanda

V1 - 90° para RT28

(*) - IEC71-B14 (FRS50)

Dimensiones motores: ver página 25

Dimensiones sin compromiso

Reductores Serie RS y RT

Dimensiones

Accesorios RT

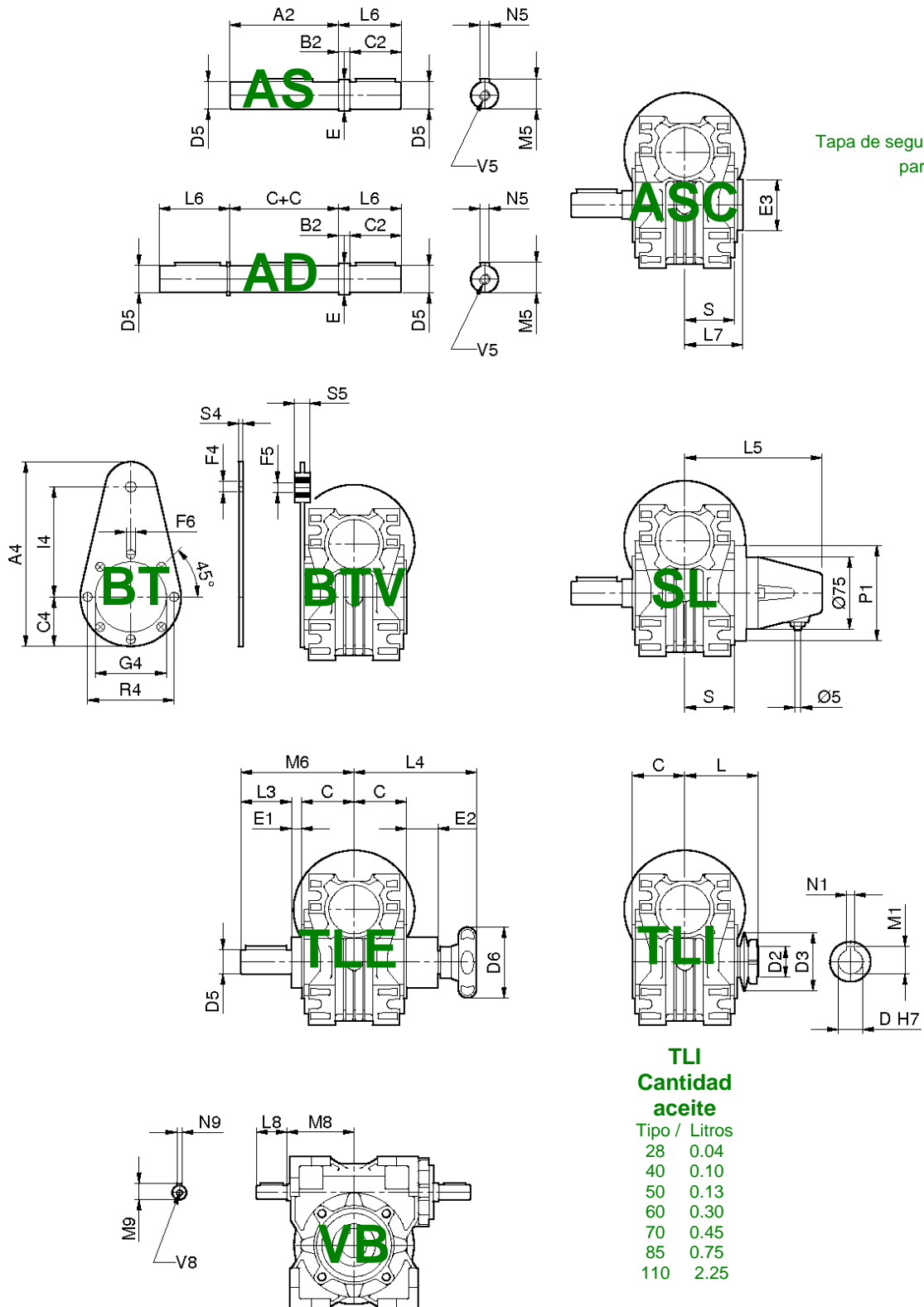

Reductores Serie RS y RT

Accesorios RT

Dimensiones

RT	28	40	50	60	70	85	110
AS & AD A ₂	58	80	95	117	117	119	153
B ₂	1	10	10	10	10	10	10
C	30	41	49	60	60	61	77.5
C ₂	30	40	45	50	60	70	100
D ₅ (g6)	14	19 (18)	24 (25)	25	28	32 (35)	42
E	14	22	28	30	34	38	50
L ₆	31	50	55	60	70	80	110
M ₅	16	21.5	27	28	31	35	45
N ₅	5	6	8	8	8	10	12
V ₅	M5x10	M8x20	M8x20	M8x20	M8x20	M10x25	M10x25
ASC E ₃	50	52	62	75	90	100	120
L ₇	36	48.5	55.5	68.5	67	77	85
S	27.5	38.5	46.5	57	57	67	74
BT & BTV A ₄	138	168	185	235	295	313	388
C ₄	38	43	60	55	65	75	100
F ₄	10.5	10.5	10.5	10.5	10.5	20.5	20.5
F ₅	10	10	10	10	10	20	20
F ₆	7	7	9	9	9	12	13
G ₄	55	60	70	80	95	110	130
I ₄	80	100	100	150	150	200	250
R ₄	65	75	85	95	115	130	165
S ₄	4	4	4	6	6	6	6
S ₅	15	15	15	20	20	25	25
SL L ₅	96	113	123	133	133	139	150
P ₁	78	90	100	110	130	160	200
S	27.5	38.5	46.5	57	57	67	74
TLE D ₆	52	70	70	70	80	100	100
E ₁	10	12	12	15	14	19	24
E ₂	28	37	31	40	46	57	71
L ₃	30	40	50	50	60	70	80
L ₄	94	116	118	128	146	168	201
M ₆	70	93	111	125	134	150	181
TLI D (H7)	14	19	24	25	28	32	42
D ₂	40	56	71	71	80	90	125
D ₃	14.2 x 20	19.5 x 20.5	24.5 x 28	25.5 x 26	28.5 x 22	32.5 x 27	42.5 x 38.5
L	45	61.5	77	86.5	89	94	109
M ₁	15.4*	21.8	27.3	27.3*	31.3	35.3	45.3
N ₁ (H9)	5	6	8	8	8	10	12
VB D ₉	9	11	14	19	19	24	28
L ₈	20	23	30	40	40	50	60
M ₈	43	55	65	77	84	106.5	145
M ₉	10.2	12.5	16	22.5	22.5	27	31
N ₉	3	4	5	6	6	8	8
V ₈	M4x10	M4x10	M6x15	M8x20	M8x20	M8x20	M8x20

D₅ (..) = Diámetro sobre demanda

* = Chaveta rebajada

Dimensiones sin compromiso

Reductores Serie RS y RT

Dimensiones

Tren de engranajes XA

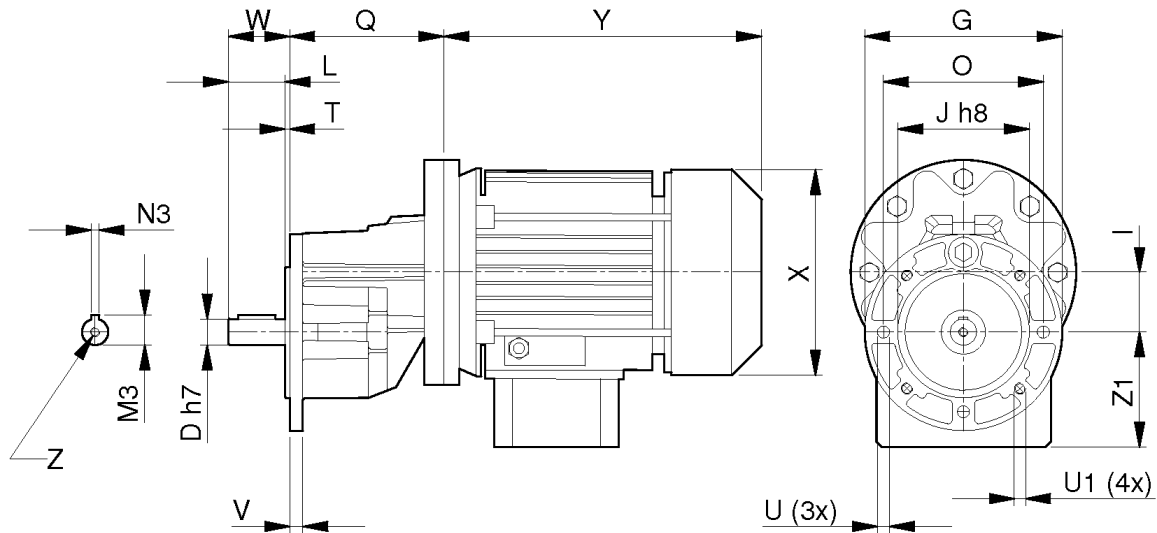

XA	D _{H7}	G	I	J _{h8}	L	O	Q	U	U1	T	V	W	Z
63	14	105	32	70	30	85	83	6.5	M6	2.5	7	32.5	M5x10
71	19	120	40	80	40	100	90	5.5	M6	2.5	7.5	42.5	M8x20
80	24	140	50	95	49.5	115	114	9	M8	2.5	10.5	52	M8x20
100	28	200	63	130	57.5	165	177	10.5	10.5	2.5	12	60	M10 x 22

IEC	56	63	71	80	90 S / L	100	112
H	108	110	121	138	149	160	160
X	168	185	215	238	255 / 280	309	309
Y	110	123	140	159	176	195	195

Reductores Serie RS y RT

Reversibilidad e Irreversibilidad

Accionando un reductor de vis-sin-fin al revés utilizando la corona como órgano motriz, el rendimiento es inferior al accionamiento por el vis, y variando algunos datos de diseño, el rendimiento puede ser reducido a cero, obteniendo la irreversibilidad del engrane.

En este accionamiento al revés, la fricción interna tiende a bloquear el engrane y, cuanto mayor sea el par aplicado sobre la corona motriz, mas aumenta proporcionalmente la fricción del engrane obstaculizando la rotación.

El ejemplo más obvio viene dado por el frenado o descenso de una carga por inercia, donde el par externo tiende a accionar el vis en sentido contrario.

Un reductor de vis-sin-fin se considera irreversible cuando el ángulo de la hélice es inferior al ángulo de fricción (arcotangente del coeficiente de fricción).

El contacto sobre el dentado es dinámico aún cuando la velocidad de engrane es cero, en cuanto que las vibraciones sobre un engranaje que no gira, pueden originar un movimiento en la zona de contacto.

Se aconseja como factor de seguridad la selección de un ángulo de la hélice de 3° para las condiciones de máxima irreversibilidad y de 10° para irreversibilidad mínima, según la tabla de las relaciones entre el ángulo de la hélice y la irreversibilidad.

Hélice	Irreversibilidad estática
$\beta > 20^\circ$	Reversibilidad plena
$10^\circ < \beta < 20^\circ$	Reversibilidad elevada
$5^\circ < \beta < 10^\circ$	Reversibilidad buena Irreversibilidad escasa
$3^\circ < \beta < 5^\circ$	Reversibilidad escasa Irreversibilidad buena
$1^\circ < \beta < 3^\circ$	Irreversibilidad plena

Reductores Serie RS y RT

Reversibilidad e Irreversibilidad

	i =	5	7	10	15	20	28	40	49	56	70	80	100
RS/RT 28	m_x		1.50	1.40	1.40	1.10	1.50	1.10	0.90	0.75	0.60	0.55	0.45
	β	---	23°11'	16°41'	11°18'	10°23'	6°06'	5°14'	4°19'	3°03'	2°27'	2°37'	2°20'
	z_1		4	3	2	2	1	1	1	1	1	1	1
RS/RT 40	m_x	2,00	2.10	2.00	2.00	1.50	2.10	1.50	1.25	1.10	0.90	0.80	0.65
	β	30°57'	21°36'	16°41'	11°18'	8°31'	5°39'	4°17'	3°48'	3°25'	3°01'	2°51'	2°38'
	z_1	6	4	3	2	2	1	1	1	1	1	1	1
RS/RT 50	m_x	2,50	2.70	2.50	2.50	1.90	2.70	1.90	1.60	1.40	1.10	1.00	0.80
	β	30°57'	23°52'	16°41'	11°18'	5°59'	6°19'	4°31'	4°14'	3°42'	2°44'	2°51'	2°17'
	z_1	6	4	3	2	2	1	1	1	1	1	1	1
RS/RT 60	m_x	3,15	3.30	3.10	3.10	2.40	3.30	2.40	2.00	1.70	1.40	1.20	1.00
	β	36°32'	25°33'	19°0'	12°55'	11°18'	6°49'	5°42'	5°11'	3°55'	3°38'	2°51'	2°51'
	z_1	6	4	3	2	2	1	1	1	1	1	1	1
RS/RT 70	m_x	3,60	3.90	3.60	3.60	2.80	3.90	2.80	2.30	2.00	1.60	1.40	1.15
	β	34°01'	26°51'	18°38'	12°40'	11°18'	7°12'	5°42'	4°48'	4°05'	3°16'	2°51'	2°38'
	z_1	6	4	3	2	2	1	1	1	1	1	1	1
RS/RT 85	m_x	4,40	4.70	4.40	4.40	3.40	4.70	3.40	2.80	2.50	2.00	1.74	1.40
	β	34°47'	26°05'	19°09'	13°02'	11°18'	6°58'	5°52'	4°52'	4°45'	3°48'	3°14'	2°40'
	z_1	6	4	3	2	2	1	1	1	1	1	1	1
RS/RT 110	m_x		6.10	5.80	5.80	4.40	6.10	4.40	3.60	3.20	2.60	2.30	1.80
	β	---	26°22'	20°43'	14°09'	11°18'	7°04'	5°42'	4°43'	4°29'	3°54'	3°39'	2°34'
	z_1		4	3	2	2	1	1	1	1	1	1	1
RS 130	m_x		7.25	6.90	6.85	5.35	7.25	5.30	4.35	4.00	3.15	2.70	2.25
	β	---	26°57'	21°20'	14°06'	13°5'	7°14'	6°18'	5°18'	6°20'	4°33'	3°30'	3°40'
	z_1		4	3	2	2	1	1	1	1	1	1	1
RS 150	m_x		8.25	8.00	8.15	6.20	8.45	6.25	5.10	4.60	3.60	3.15	2.60
	β	---	25°33'	21°48'	16°22'	13°24'	7°35'	7°07'	5°48'	6°11'	4°17'	3°45'	3°43'
	z_1		4	3	2	2	1	1	1	1	1	1	1

m_x = Módulo axial
 z_1 = N. entradas
 β = Angulo de la hélice (derecho)
 20° = Angulo de presión

Reductores Serie RS y RT

Sentido de Rotación

VIS SIN FIN EN ALTO

RS - RT

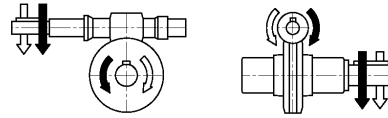

RA - TA

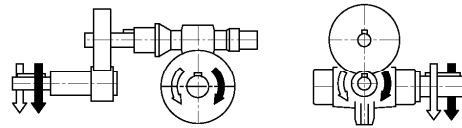

**RS/RS
RT/RT**

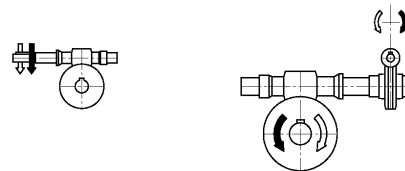

VIS SIN FIN EN BAJO

RS - RT

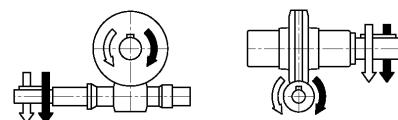

RA - TA

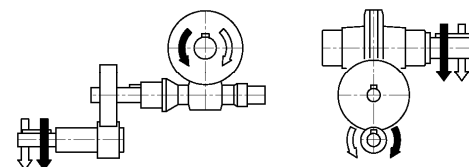

**RS/RS
RT/RT**



Reductores Serie RS y RT

Extracto de las INSTRUCCIONES DE USO Y MANTENIMIENTO

Los grupos reductores y variadores no entran en campo de aplicación de la Directiva Máquinas, Art. 1(2), y no pueden ser puestos en servicio hasta que la máquina a la que deben ser incorporados, haya sido declarada conforme al Art. 4(2), Anexo II (B) de la Directiva Máquinas 98/37/CEE/22.6.98 y para Italia, el DL 459/24.7.96.

Las instrucciones deben ser ejecutadas por personal formado y cualificado y, en el caso de la Directiva Atex, con experiencia específica en la seguridad de zonas potencialmente explosivas.

Instalación

Verificar que el grupo a instalar tenga las características aptas para realizar la función requerida y que la posición de montaje sea acorde con el pedido. Tales características figuran en la placa de características del aparato. Verificar la estabilidad del montaje para evitar vibraciones o sobrecargas durante el funcionamiento, cuyos efectos pueden ser limitados por amortiguadores o limitadores de par.

Funcionamiento

Según el conexionado del motor los grupos pueden girar en sentido horario o anti-horario: reductores con número de trenes de engranajes par conservan el sentido de giro del motor, con número impar lo invierten. Parar inmediatamente el grupo en caso de funcionamiento defectuoso o ruido anormal, eliminar el defecto o devolver el aparato a fábrica para una adecuada revisión. Si la parte defectuosa no es sustituida, otras partes pueden resultar dañadas y se hace difícil identificar la causa.

Mantenimiento

Si bien los grupos han sido probados sin carga antes de la expedición, es aconsejable no usarlos a plena carga durante las primeras 20-30 horas de funcionamiento con el fin de permitir que las partes internas se adapten recíprocamente. Los reductores se entregan llenados de aceite de base sintética de larga duración. Si es necesario cambiar o añadir aceite no mezclar aceite de base sintética con aceite de base mineral.

Instalación

Para el levantamiento por grúa, utilizar el gancho provisto en la carcasa o en defecto los agujeros de las patas o de las bridas, evitando utilizar las partes móviles.

Las instrucciones deben ser ejecutadas por personal formado y cualificado y, en el caso de la Directiva Atex, con experiencia específica en la seguridad de zonas potencialmente explosivas.

Pintura

Si se precisa pintar el grupo después de su instalación, proteger los retenes, planos de apoyo y los ejes.

Conservación prolongada en almacén

Para permanencias superiores a los tres meses, es una buena norma aplicar antioxidante sobre los ejes y planos mecanizados (cuando son de fundición), prestando especial atención a las zonas de trabajo del labio de los retenes. Un almacenamiento superior a un año reduce la vida de la grasa de los rodamientos.

Gestión Ambiental del producto

En conformidad a la Certificación Ambiental ISO 14001, recomendamos seguir las siguientes indicaciones para el desguace de nuestros productos:

- los componentes del grupo que sean para chatarra, deberán ser entregados a centros de recogida autorizados para materiales metálicos;
- aceites y lubricantes recogidos del grupo deberán ser entregados a centros de tratamiento de aceites usados;
- embalajes (palets, cartón, papel, plástico, etc.) deben ser orientados en lo posible hacia su recuperación / reciclaje, entregándolos a empresas autorizadas para cada tipo de residuo.

Directiva 84/9/CE - ATEX

La Directiva concierne no solo las máquinas eléctricas, pero también todo aparato o elemento de control a ser utilizados en atmósferas potencialmente explosivas.

Los productos VARVEL-ATEX están diseñados y fabricados de acuerdo con la Directiva 94/9/CE y por ello están cualificados para su instalación en atmósferas potencialmente explosivas.