

RC

RIDUTTORI AD INGRANAGGI HELICAL GEARBOXES STIRNRADGETRIEBE



RC Riduttori ad ingranaggi

Una, due e tre coppie di riduzione

- 7 grandezze
- Potenze da 0.09 a 22 kW
- Rapporti da 1.5:1 a 3620:1
- Coppie da 20 a 2500 Nm



RC Helical speed reducers

One, two and three reduction stages

- 7 sizes
- Powers from 0.09 to 22 kW
- Ratios from 1.5:1 to 3620:1
- Torques from 20 to 2500 Nm



RC Stirnradgetriebe

Eniz, Zwei und Drei Stufen

- 7 Größen
- Leistungen von 0.09 bis 22 kW
- Untersetzungen von 1.5:1 bis 3620:1
- Ausgangsdrehmoment von 20 bis 2500 Nm

VARVEL - RC

RIDUTTORI SERIE RC
GEARBOXES SERIES RC
GETRIEBEBAUREIHE RC

La serie dei riduttori a ingranaggi tipo RC è costruita secondo le norme di progettazione ISO.

La struttura compatta della carcassa non subisce deformazioni significative sotto effetto della coppia di funzionamento e dei carichi esterni con positivi risultati sulle superfici di tenuta.

I riduttori serie RC sono costruiti con carcassa realizzata in forma B3 con piedi o in forma B5.

La lavorazione in unico piazzamento con linee di produzione CNC dell'ultima generazione e i più moderni processi di calcolo e controllo originano una superiore affidabilità di funzionamento, le massime coppie disponibili, elevati carichi radiali ed assiali e lunga vita operativa.

The Series RC helical gearboxes are manufactured to latest ISO engineering design specifications.

Significant strains caused by the effects of torque and external loads do not deflect the monolithic ribwork of the housing, which significantly improves the integrity of the sealed surfaces.

The Series RD helical gearboxes are manufactured in B3 base mounted configuration and in B5 flange mounting.

Single-setup machining on state-of-the-art CNC production lines, the most recent calculation techniques and process controls give superior operational reliability, maximum output torques, high overhung and thrust load capacity, and long working life-time.

Die Stirnradgetriebe die Baureihe RD besitzen ein einteiliges Gussgehäuse, welches die Aufnahme von 2 oder 3 Getriebestufen im gleichen Gehäuse ermöglicht. Die Entwicklung erfolgte nach den neuesten ISO-Vorschriften unter Berücksichtigung von Strukturanalysen zur Überprüfung der Verformungs-Beständigkeit.

Durch Drehmomente und einwirkende äußere Kräfte entstehen keine beachtenswerten Verspannungen des monolithischen Gehäuses mit Einfluss auf die Dichtflächen.

Die Gehäuse sind immer in Bauform B3 ausgeführt mit entsprechender Vorbereitung für Umrüstung in Bauform B5, wobei hier verschiedene Flansche zur Verfügung stehen.

Durch Zusammenfassung modernster Maschinen in CNC-Produktionslinien, durch fortschrittlichste Berechnungsverfahren und durch permanente Kontrolle der Produktion werden höchste Zuverlässigkeit, große Drehmomente, hohe Achsbelastbarkeit und Stoss-festigkeit bei langer Lebensdauer erreicht.

	SPECIFICHE GENERALI	GENERAL SPECIFICATIONS	ALLGEMEINE EIGENSCHAFTEN
Gamma Range Bereich	7 grandezze 40 rapporti in 1, 2 e 3 coppie 2500 Nm coppia uscita max	7 sizes 40 ratios in 1, 2 and 3 stages 2500 Nm max. output torque	7 Baugrößen 40 Übersetzungen 1, 2 u. 3-stufig 2500 Nm max. Abtriebsmoment
Dimensionamento Sizing Auslegung	Secondo ISO6336 / DIN3990. Vita media 15.000 ore con fattore di servizio SF1	According to ISO6336/DIN3990. 15,000 hrs average lifetime with service factor SF1	Laut ISO6336/DIN3990. 15.000 Stunden Lebensdauer für Verzahnung und Lagerung bei einem Betriebsfaktor SF1
Carcassa, Coperchi Housing, Covers Gehäuse, Flansche	Ghisa grigia G25	Grey cast iron G25	Grauguss G25
Parti dentate Toothed parts Verzahnung	Acciaio 20MnCr5 cmt / tmp. Evolvente sbarbato.	Steel 20MnCr5 case hardened. Tooth profile shaved	Stahl 20MnCr5 einsatzgehärtet. Zahnprofil geschliffen.
Alberi & Linguette Shafts & Keys Wellen	Acciaio 39NiCrMo3 Alberi k6 - Fori E8 Linguette secondo DIN6885 B1	Steel 39NiCrMo3 Shafts k6 - Bores E8 Keys according to DIN6885 B1	Stahl 39NiCrMo3 Wellen k6 – Bohrungen E8 Keile nach DIN6885 B1
Cuscinetti Bearings Lagerung	Sfere o rulli secondo grandezza e specifiche tecniche	Ball- or roller-types according to sizes and technical requirements	Kugel- oder Rollenlager entsprechend den technischen Vorschriften
Paraolio Oilseals Dichtungen	Tipo NB - nitril-butadiene con secondo labbro parapolvere secondo DIN 3760	Type NB - nitril-butadiene with additional anti-dust lip according to DIN 3760	Typ NB – Nitril-Butadien mit zusätzlicher Staublippe entsprechend DIN 3760
Lubrificante Lubricant Schmierung	Olio sintetico a lunga durata Gradazione ISO VG 320	Synthetic long-life oil Grade ISO VG 320	Synthetisches Getriebeöl ISO VG 320 als Langzeit-Füllung
Verniciatura a forno Baking painting Gehäuselackierung	Vernice a polveri epossidiche Colore standard RAL 6003	Epoxy powder paint Standard colour RAL 6003	Epoxydpulverfarbe Standardfarbton RAL 6003

VARVEL - RC

DESIGNAZIONE - FATTORI DI SERVIZIO - RENDIMENTI
 DESIGNATION - SERVICE FACTORS - EFFICIENCY
 BEZEICHNUNGEN - BETRIEBSFAKTOREN - WIRKUNGSGRAD

DESIGNAZIONE DEL RIDUTTORE GEARBOX DESIGNATION GETRIEBEBEZEICHNUNG

F RC 2 10 /B3 20 IEC71 /B14

B5, B14 = Forma del motore - Motor format - Motorbauform
 Grandezza del motore elettrico - Electric motor frame - Motorbaugröße
 Rapporto di riduzione - Reduction ratio - Getriebeübersetzung
 B3, B5 = Forma costruttiva del riduttore - Gearbox format - Bauform des Getriebes
 Grandezza del riduttore - Gearbox size - Baugröße des Getriebes
 1,2,3 = N.coppie - No of gear sets - Stufennummer
 Tipo del riduttore - Gearbox type - Getriebetyp

M = Motoriduttore - Geared motor - Getriebemotor
 F = Riduttore con flangia entrata IEC - Gearbox with input flange IEC - IEC-Eingangsfansch
 ... = Riduttore con albero entrata sporgente - Gearbox with input free shaft - Freie Eingangswelle

DESIGNAZIONE DEL MOTORE MOTOR DESIGNATION MOTORENBEZEICHNUNG

MT 0.37 kW 71B 4 B14 230/400/50 IP55 F X4

Posizione della morsettiera
 Terminal box position
 Klemmkastenposition

Class F (std) = Classe isolamento
 Insulation class
 Isolationsklasse

IP55 (std) = Grado di protezione
 Protection class
 Schutzart

Tensione/Frequenza - Voltage/frequency - Spannung/Frequenz
 Forma costruttiva - Mounting format - Bauform
 Numero poli - Number of poles - Polzahl
 Grandezza IEC motore - IEC motor frame - IEC-Motorbaugröße
 Potenza motore - Motor power - Motorleistung

MT = Motore trifase - Three-phase motor - Dreiphasenmotor
 MM = Motore monofase - Single-phase motor - Einphasenmotor
 MA = Motore autofrenante - Brake motor - Bremsmotor

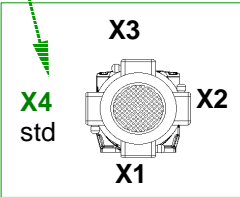

FATTORI DI SERVIZIO SERVICE FACTORS BETRIEBSFAKTOREN

F1 [h]	a	b	c	d	F2
3 - 4	0.8	1.0	1.5	6	1.0
8 - 10	1.0	1.2	1.8	60	1.2
10 - 24	1.4	1.6	2.0	120	1.4

FS = F1 x F2

	Carico	Load	Belastung
a	Uniforme	Uniform	gleichmäßige
b	Variabile	Variable	variable
c	A urti	Shock	Stoß
d	Avviam./ora	Start/Stops	Schaltungen/St.

RENDIMENTI EFFICIENCY WIRKUNGSGRAD

	η		
RC1	0.98		
RC2	0.96		
RC3	0.94		
	Coppie	Gear set	Stufig
RC1 -	Una	One	Einz-
RC2 -	Due	Two	Zwei-
RC3 -	Tre	Three	Drei-

VARVEL - RC

POSIZIONI DI MONTAGGIO - COPPIE MASSIME - CARICHI ESTERNI
 STANDARD INSTALLATIONS - MAX. OUTPUT TORQUES - EXTERNAL LOADS
 MAONTAGEPOSITION - AUSGANGSDREHMOMENT - AUSGANGSKRÄFTE

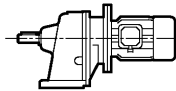

B3

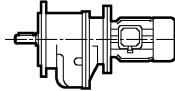

B5

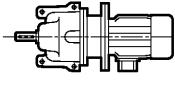

B6

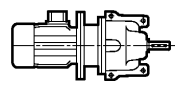

B7

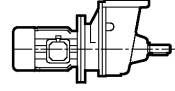

B8

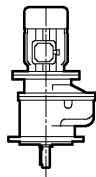

V1

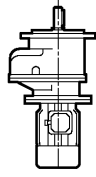

V3

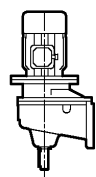

V5

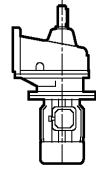

V6

COPPIE MAX. USCITA [Nm]	RC1	Nm	RC2	Nm	RC3	Nm
MAX. OUTPUT TORQUES [Nm]	105	10	205	37	305	37
MAX. AUSGANGSDREHMOMENT [Nm]	110	20	210	75	310	75
	120	42	220	150	320	150
	130	84	230	300	330	300
	140	230	240	600	340	600
	* 150	410	250	1250	350	1250
	* 160	830	260	2500	360	2500

* = In esaurimento - Discontinued model - Obsolete wird

CARICHI USCITA R2 [daN]

OUTPUT LOADS [daN]
 AUSGANGSKRÄFTE [daN]

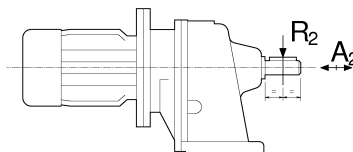

$$A2 = 0.2 \times R2$$

* = In esaurimento - Discontinued model - Obsolete wird

Una coppia One stage Einstufig	rpm	RC105	RC110	RC120	RC130	RC140	* RC150	* RC160
	1000	20	25	35	50	70	110	230
	500	30	40	55	80	110	170	350
	150	45	60	80	110	165	250	480

Due coppie Two Stages Zweistufige	rpm	RC205	RC210	RC220	RC230	RC240	RC250	RC260
	500	45	75	110	180	275	420	800
	300	60	90	125	210	320	475	950
	150	75	110	165	270	415	620	1200
	75	95	140	210	350	530	800	1600
	30	110	150	250	420	620	930	1800

Tre coppie Three stages Dreistufige	rpm	RC305	RC310	RC320	RC330	RC340	RC350	RC360
	25÷3	120	160	270	450	675	1000	1950

VARVEL - RC

SELEZIONE RIDUTTORE - MRC
SPEED REDUCER SELECTION - MRC
GETRIEBEAUSWAHL - MRC

1400 [min⁻¹]

2.2 kW (3 HP)					3 kW (4 HP)					5.5 kW (7.5 HP)							
Tipo	rpm	1:	Nm	SF	kg	Tipo	rpm	1:	Nm	SF	kg	Tipo	rpm	1:	Nm	SF	kg
MRC360	13.5	103	1465	1.7	164	MRC230	630	2.3	45	>3	46	MRC240	630	2.3	80	>3	78
MRC360	16	87	1235	2.0	164	MRC130	965	1.5	30	2.9	44	MRC140	965	1.5	55	>3	92
MRC350	19	73	1040	1.2	86						7.5 kW (10 HP)						
MRC350	23	61	860	1.5	86	4 kW (5.5 HP)					MRC260	27	52	2500	1.0	209	
MRC250	27	52	750	1.7	82	MRC360	19	73	1890	1.3	185	MRC260	31	46	2220	1.1	209
MRC250	31	46	650	1.9	82	MRC360	23	61	1560	1.6	185	MRC260	37	38	1860	1.3	209
MRC240	37	38	545	1.1	54	MRC250	27	52	1350	0.9	114	MRC260	42	34	1640	1.5	209
MRC240	42	34	480	1.2	54	MRC250	31	46	1185	1.1	114	MRC260	47	30	1465	1.7	209
MRC240	47	30	430	1.4	54	MRC250	37	38	990	1.3	114	MRC260	57	25	1210	2.1	209
MRC240	57	25	355	1.7	54	MRC250	42	34	875	1.4	114	MRC250	69	20	1000	1.3	133
MRC240	69	20	295	2.0	54	MRC250	47	30	780	1.6	114	MRC250	82	18	840	1.5	133
MRC240	82	18	245	2.4	54	MRC250	57	25	645	1.9	114	MRC250	90	16	765	1.6	133
MRC230	90	16	225	1.3	44	MRC240	69	20	530	1.1	69	MRC250	101	14	680	1.8	133
MRC230	101	14	200	1.5	44	MRC240	82	18	450	1.4	69	MRC250	113	13	610	2.1	133
MRC230	113	13	180	1.7	44	MRC240	90	16	410	1.5	69	MRC250	138	10	500	2.5	133
MRC230	138	10	150	2.0	44	MRC240	101	14	365	1.7	69	MRC250	166	8.7	415	3.0	133
MRC230	166	8.7	125	2.5	44	MRC240	113	13	325	1.8	69	MRC150	175	8.3	400	1.0	111
MRC140	175	8.3	120	1.9	50	MRC240	138	10	265	2.3	69	MRC250	196	7.3	350	>3	133
MRC230	196	7.3	105	2.9	44	MRC240	166	8.7	220	2.7	69	MRC250	210	6.8	330	>3	133
MRC230	210	6.8	95	>3	44	MRC140	175	8.3	215	1.1	72	MRC250	230	6.3	300	>3	133
MRC230	230	6.3	90	>3	44	MRC240	196	7.3	190	>3	69	MRC250	240	6.0	290	>3	133
MRC230	240	6.0	85	>3	44	MRC240	210	6.8	175	>3	69	MRC240	268	5.4	260	2.3	88
MRC230	268	5.4	75	>3	44	MRC240	230	6.3	160	>3	69	MRC240	324	4.5	215	2.8	88
MRC230	324	4.5	65	>3	44	MRC240	240	6.0	155	>3	69	MRC240	388	3.7	180	>3	88
MRC230	388	3.7	55	>3	44	MRC230	268	5.4	135	>3	59	MRC150	415	3.5	170	2.4	111
MRC130	415	3.5	50	1.7	41	MRC230	324	4.5	115	>3	59	MRC240	460	3.1	150	>3	88
MRC230	460	3.1	45	>3	44	MRC230	388	3.7	95	>3	59	MRC240	540	2.7	130	>3	88
MRC230	540	2.7	40	>3	44	MRC140	415	3.1	90	2.5	72	MRC240	630	2.3	110	>3	88
MRC230	630	2.3	35	>3	44	MRC230	460	3.1	80	>3	59	MRC140	965	1.5	75	>3	103
MRC130	965	1.5	25	>3	41	MRC230	540	2.7	70	>3	59	11 kW (15 HP)					
3 kW (4 HP)					MRC230	630	2.3	60	>3	59	MRC260	47	30	2150	1.2	219	
MRC360	12.0	119	2250	1.1	167	MRC140	965	1.5	40	>3	72	MRC260	57	25	1770	1.4	219
MRC360	13.5	103	2000	1.3	167	5.5 kW (7.5 HP)					MRC260	69	20	1460	1.7	219	
MRC360	16	87	1685	1.5	167	MRC360	19	73	2500	1.0	205	MRC260	82	18	1230	2.0	219
MRC350	19	73	1415	0.9	101	MRC360	23	61	2145	1.2	205	MRC260	90	16	1120	2.2	219
MRC350	23	61	1170	1.1	101	MRC260	27	52	1870	1.3	199	MRC260	101	14	1000	2.3	219
MRC250	27	52	1020	1.2	88	MRC260	31	46	1630	1.5	199	MRC260	113	13	895	2.8	219
MRC250	31	46	890	1.4	88	MRC260	37	38	1365	1.8	199	MRC260	138	10	730	3.0	219
MRC250	37	38	745	1.7	88	MRC260	42	34	1200	2.1	199	MRC250	166	8.7	610	2.0	148
MRC250	42	34	655	1.9	88	MRC260	47	30	1075	1.2	123	MRC160	175	8.3	580	1.4	185
MRC240	47	30	590	1.0	56	MRC250	57	25	885	1.4	123	MRC250	196	7.3	515	2.4	148
MRC240	57	25	485	1.2	56	MRC250	69	20	730	1.7	123	MRC250	210	6.8	480	2.6	148
MRC240	69	20	400	1.5	56	MRC250	82	18	615	2.0	123	MRC250	230	6.3	440	2.8	148
MRC240	82	18	335	1.8	56	MRC250	90	16	560	2.2	123	MRC250	240	6.0	420	3.0	148
MRC240	90	16	305	2.0	56	MRC250	101	14	500	2.5	123	MRC250	268	5.4	380	>2	148
MRC240	101	14	275	2.2	56	MRC250	113	13	450	2.8	123	MRC250	324	4.5	310	>2	148
MRC240	113	13	245	2.5	56	MRC250	138	10	365	>3	123	MRC250	388	3.7	260	>2	148
MRC240	138	10	200	3.0	56	MRC240	166	8.7	305	1.9	78	MRC150	415	3.5	250	1.6	141
MRC230	166	8.7	165	1.8	46	MRC240	175	8.3	295	1.4	110	MRC250	460	3.1	220	>2	148
MRC140	175	8.3	160	1.4	53	MRC240	196	7.3	260	2.3	78	MRC250	540	2.7	190	>2	148
MRC230	196	7.3	140	2.1	46	MRC240	230	6.3	220	2.7	78	MRC250	630	2.3	160	>2	148
MRC230	210	6.8	130	2.3	46	MRC240	240	6.0	210	2.8	78	MRC150	965	1.5	110	>2	141
MRC230	230	6.3	120	2.5	46	MRC240	268	5.4	190	>3	78	15 kW (20 HP)					
MRC230	240	6.0	115	2.6	46	MRC240	324	4.5	155	>3	78	MRC260	69	20	2000	1.3	240
MRC230	268	5.4	105	2.9	46	MRC240	388	3.7	130	>3	78	MRC260	82	18	1680	1.5	240
MRC230	324	4.5	85	>3	46	MRC150	415	3.5	125	>3	110	MRC260	90	16	1530	1.6	240
MRC230	388	3.7	70	>3	46	MRC240	460	3.1	110	>3	78	MRC260	101	14	1360	1.8	240
MRC130	415	3.5	70	1.2	44	MRC240	540	2.7	95	>3	78	MRC260	113	13	1220	2.1	240
MRC230	460	3.1	60	>3	46												
MRC230	540	2.7	50	>3	46												

1400 [min⁻¹]

VARVEL - RC

SELEZIONE RIDUTTORE - MRC
SPEED REDUCER SELECTION - MRC
GETRIEBEAUSWAHL - MRC

15 kW (20 HP)					15 kW (20 HP)					18.5 kW (25 HP)				
Tipo	rpm	1:	Nm	SF kg	Tipo	rpm	1:	Nm	SF kg	Tipo	rpm	1:	Nm	SF kg
MRC260	138	10	1000	2.5 240	MRC250	630	2.3	220	>3 178	MRC260	460	3.1	360	>3 260
MRC260	166	8.7	830	3.0 240	MRC150	965	1.5	145	>3 171	MRC260	540	2.7	310	>3 260
MRC160	175	8.3	800	1.0 215						MRC260	630	2.3	265	>3 260
MRC260	196	7.3	700	>3 240						MRC160	965	1.5	180	>3 225
MRC260	210	6.8	660	>3 240	18.5 kW (25 HP)									
MRC260	230	6.3	600	>3 240	MRC260	166	8.8	1000	2.5 260					
MRC260	240	6.0	575	>3 240	MRC260	196	7.3	850	2.9 260	22 kW (30 HP)				
MRC250	268	5.4	515	>3 178	MRC260	210	6.8	790	>3 260	MRC260	268	5.4	755	>3 300
MRC250	324	4.5	425	>3 178	MRC260	230	6.3	725	>3 260	MRC260	324	4.5	625	>3 300
MRC250	388	3.7	355	>3 178	MRC260	240	6.0	695	>3 260	MRC260	388	3.7	520	>3 300
MRC160	415	3.5	340	2.5 215	MRC260	268	5.4	620	>3 260	MRC260	460	3.1	440	>3 300
MRC250	460	3.1	300	>3 178	MRC260	324	4.5	515	>3 260	MRC260	540	2.7	375	>3 300
MRC250	540	2.7	255	>3 178	MRC260	388	3.7	430	>3 260	MRC260	630	2.3	320	>3 300
					MRC160	415	3.5	420	2.0 225	MRC160	965	1.5	215	>3 275

GRANDEZZA MOTORI IEC - MOTOR FRAMES IEC - MOTORGRÖÖE IEC

Tipo, Type, Typ	IEC (kW) 4p i=	56 0.09	63 0.13-0.18	71 0.25-0.37	80 0.55-0.75	90 1.1-1.5	100 2.2-3.0	112 4.0	132 5.5-7.5	160 11.15	180 18.5-22
FRC105	1.5-3.5 8.3	☉	★	★							
FRC205	2.3-16 18-52	☉	★	★							
FRC305	61-133 147-432	☉	★	★							
FRC110	1.5-3.5 8.3		★	★	☉★						
FRC210	2.3-16 18-52		★	★	☉★						
FRC310	61-133 147-432	☉	★	★							
FRC120	1.5-3.5 8.3		★	★	★	★					
FRC220	2.3-16 18-52		★	★	★	★					
FRC320	61-133 147-432		★	★	☉★						
FRC130	1.5-3.5 8.3			★	★	★	★	★			
FRC230	2.3-16 18-52			★	★	★	★	★			
FRC330	61-133 147-432		★	★	★	★					
FRC140	1.5-3.5 8.3			★	★	★	★	★	★		
FRC240	2.3-16 18-52			★	★	★	★	★	★		
FRC340	61-133 147-432			★	★	★	★	★			
* FRC150	1.5-3.5 8.3						★	★	★	★	
FRC250	2.3-16 18-52						★	★	★	★	
FRC350	61-133 147-432			★	★	★	★	★	★		
* FRC160	1.5-3.5 8.3									★	★
FRC260	2.3-16 18-52									★	★
FRC360	61-133 147-432						★	★	★	★	

* = In esaurimento - Discontinued model - Obsolete wird / ★ B5 - ☉ B14

1 COPPIA
 1 STAGE
 1 STUFIG

VARVEL - RC

DIMENSIONI DI INGOMBRO
 OVERALL DIMENSIONS
 ABMESSUNGEN

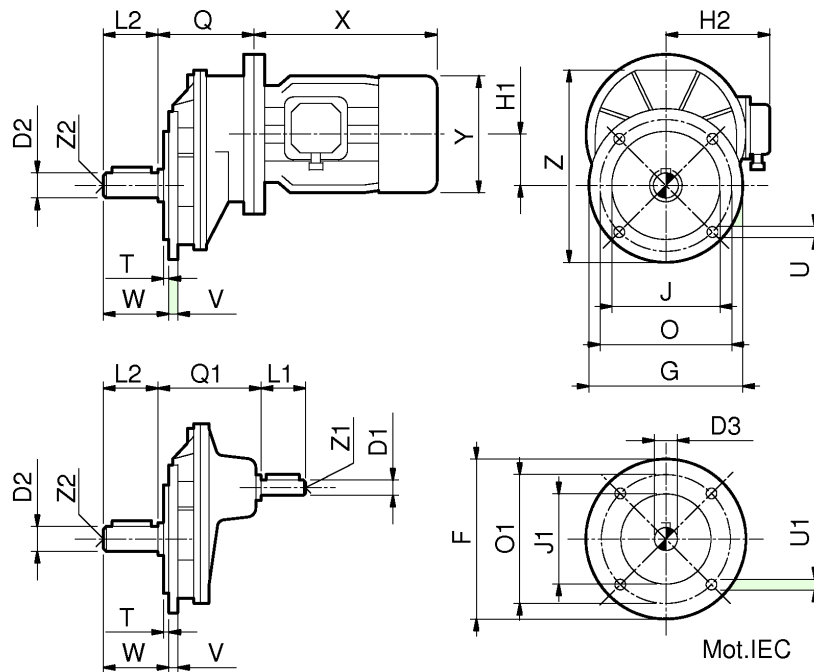
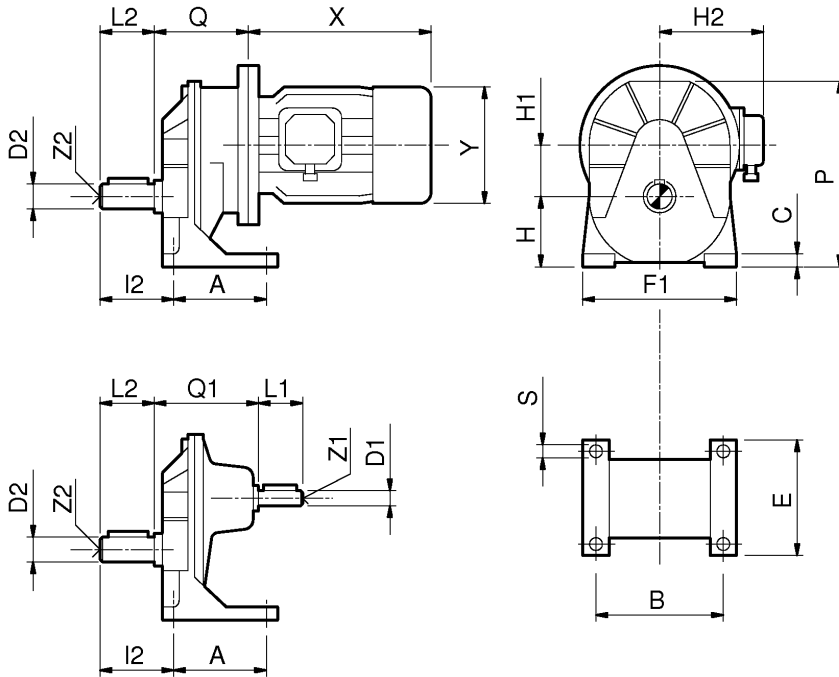

VARVEL - RC

DIMENSIONI DI INGOMBRO
OVERALL DIMENSIONS
ABMESSUNGEN

MRC	105	110	120	130	140	*150	*160
A	65	80	95	115	140	170	210
B	90	110	150	170	205	250	310
C	10	11	12	14	20	30	35
D _{1 K6}	11	11	14	19	24	28	38
D _{2 K6}	14	19	24	28	32	42	50
E	85	100	115	140	170	205	260
F ₁	110	130	180	200	250	310	400
G	140	160	200	250	300	350	450
H	50	60	75	95	115	155	200
H ₁	37.4	45	60	75	90	120	150
I ₂	40	53	62	76	100	122	140
J ₁₆	95	110	130	180	230	250	350
L ₁	30	30	30	40	50	80	80
L ₂	30	40	50	60	80	100	110
O	115	130	165	215	265	300	400
P	130.4	155	199	248	299	398	503
Q	68 (IEC56) 70 (IEC63) 80 (IEC71)	73 (IEC63) 83 (IEC71) 83 (IEC80)	99 (IEC80) 99 (IEC90) ---	118 ¹ (IEC90) 119 ² (IEC100) ---	140 (IEC100) 141 (IEC112) 153 (IEC132)	180 (IEC132) 220 (IEC160) ---	223 (IEC160) 223 (IEC180) ---
Q ₁	74	84	100	118 ³	138	169	207
S	8.5	8.5	8.5	10.5	12.5	16.5	18.5
T	2	2.5	2.5	2.5	2.5	3	3
U	M6	M8	M8	M10	M12	M16	M18
V	8	9	10	11	14	18	24
W	34	45.5	54.5	66.5	87.5	108	118
Z	130.4	175	224	278	334	418	529
Z ₁	M4 x 10	M4 x 10	M5 x 12	M6 x 15	M8 x 20	M8 x 20	M10 x 25
Z ₂	M5 x 12	M6 x 15	M8 x 20	M8 x 20	M10 x 25	M12 x 30	M14 x 35

¹ = 131.5 (FRC130/B5)

² = 132.5 (FRC130/B5)

³ = 132.5 (RC130/B5)

* = In esaurimento - Discontinued model - Obsolete wird

IEC	56 (B14)	63	71	80 (B14)	90 S/L	100	112	132 S/M	160	180 M/L
D ₃	9	11	14	19	24	28	28	38	42	48
F	120 (80)	140	150	200 (120)	200	250	250	300	350	350
H ₂	85	95	107	122	128	140	140	180	230	230/257
J ₁₆	80 (50)	95	110	130 (80)	130	180	180	230	250	250
O ₁	100 (65)	115	130	165 (100)	165	215	215	265	300	300
U ₁	7 (M5)	9	9	11 (M6)	11	14	14	14	18	18
X	156	185	215	28	255/280	309	328	368/405	538	538/613
Y	110	123	140	159	176	195	219	258	314	368

Dimensioni non impegnative - Not binding dimensions - unverbindliche Abmessungen

2 COPPIE
 2 STAGES
 2 STUFIGE

VARVEL - RC

DIMENSIONI DI INGOMBRO
 OVERALL DIMENSIONS
 ABMESSUNGEN

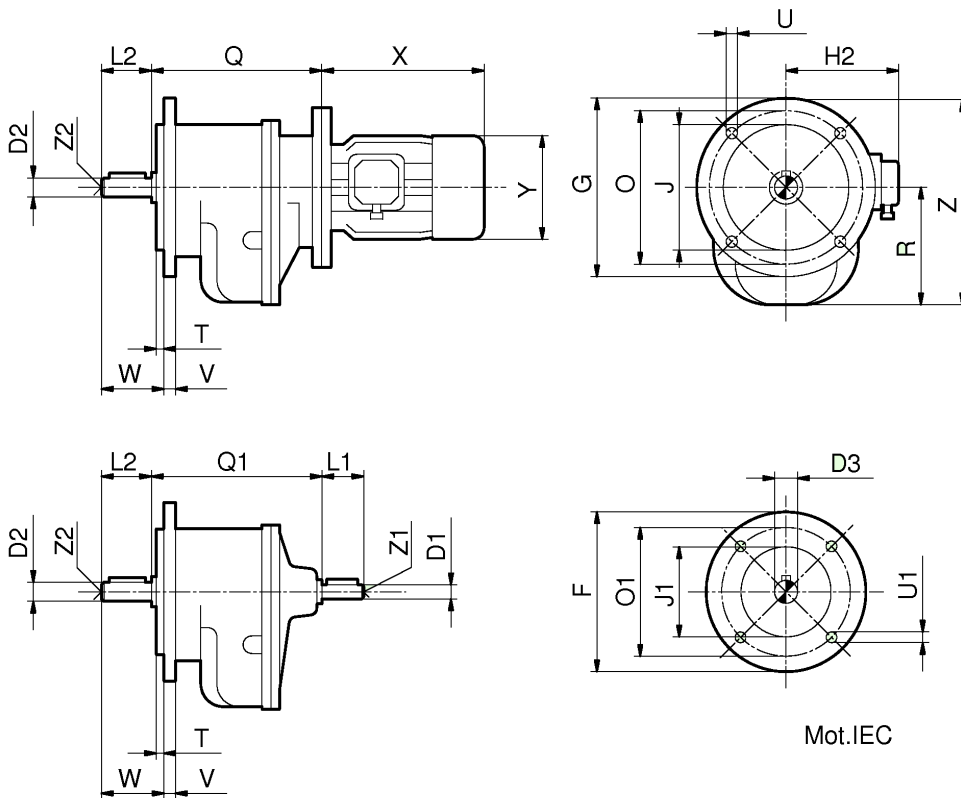
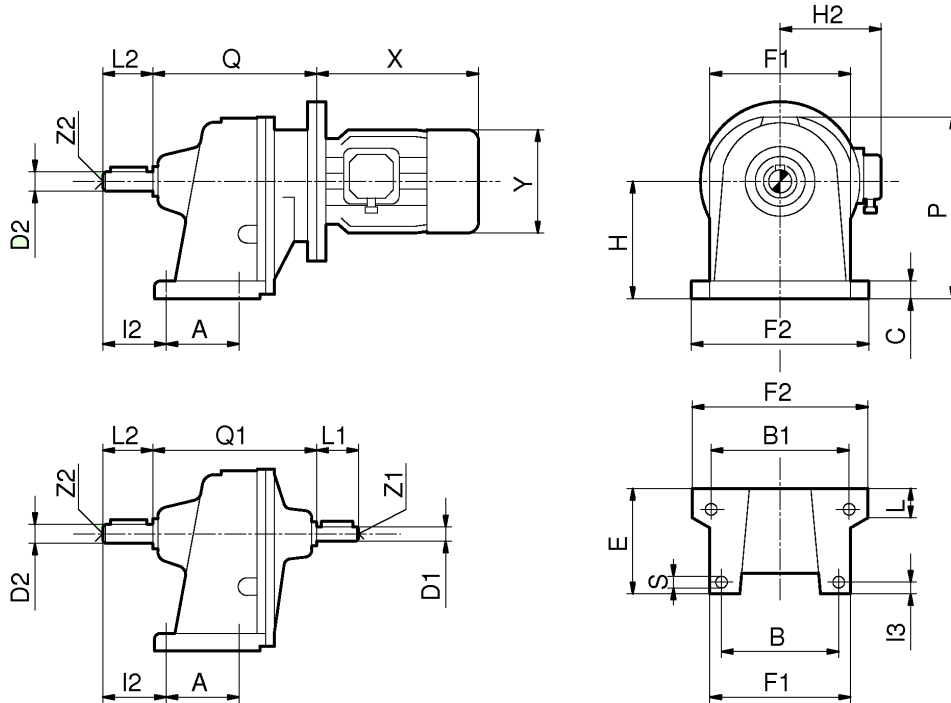

VARVEL - RC

DIMENSIONI DI INGOMBRO
OVERALL DIMENSIONS
ABMESSUNGEN

MRC	205	210	220	230	240	250	260
A	57	58	65	85	105	140	185
B	90	110	140	160	190	250	310
B ₁	113	125	157	187	223	283	352
C	8	9	14	17	20	28	29
D _{1 k6}	11	11	14	19	24	28	38
D _{2 k6}	17	20	25	32	40	50	65
E	85	90	105	128	154	196	260
F ₁	110	130	170	190	220	290	360
F ₂	135	146	185	215	260	330	400
G	140 (120/160)	160 (120/140)	200 (160)	250 (200)	300 (250)	350 (300)	450
H	81	96	126	155	185	245	305
I ₂	45	54	67	99	111	136	164
I ₃	7.5	10	13	14	15	20	23
J _{j6}	95 (80/110)	110 (80/95)	130 (110)	180 (130)	230 (180)	250 (230)	350
L	32	32	37	47	52	62	87
L ₁	30	30	30	40	50	80	80
L ₂	35	40	50	80	90	110	14
O	115 (100/130)	130 (100/115)	165 (130)	215 (165)	265 (215)	300 (265)	400
P	130	150	195	240	285	375	468
Q	125 (IEC56) 127 (IEC63) 137 (IEC71)	134 (IEC63) 144 (IEC71) 154 (IEC80)	160 (IEC71) 175 (IEC80) 175 (IEC90)	207 (IEC80-90) 208 (IEC100) 208 (IEC112)	238 (IEC90) 248 (100-112) 260 (IEC132)	287 (100-112) 317 (IEC132) 3517 (IEC160)	376 (IEC132) 414 (IEC160) 414 (IEC180)
Q ₁	131	145	176	208	245	310	398
R	80	95	124	153	184	243	304
S	9	9	11	13	15	17	19
T	2	2.5	2.5	2.5	2.5	2.5	3
U	10.5	10.5	11.5	14.5	14.5	18.5	22
V	8	10	10	12	16	20	25
W	39.5	46.5	53	87.5	98.5	118.5	147
Z	151 (140/160)	175 (155/165)	224 (204)	278 (253)	334 (309)	418 (393)	529
Z ₁	M4x10	M4x10	M5x12	M6x15	M8x20	M8x20	M10x25
Z ₂	M6x15	M6x15	M8x20	M10x25	M12x30	M14x35	M14x35

IEC	56 (B14)	63	71	80 (B14)	90 S/L	100	112	132 S/M	160	180 M/L
D ₃	9	11	14	19	24	28	28	38	42	48
F	120 (80)	140	150	200 (120)	200	250	250	300	350	350
H ₂	85	95	107	122	128	140	140	180	230	230/257
J _{1 j6}	80 (50)	95	110	130 (80)	130	180	180	230	250	250
O ₁	100 (65)	115	130	165 (100)	165	215	215	265	300	300
U ₁	7 (M5)	9	9	11 (M6)	11	14	14	14	18	18
X	156	185	215	28	255/280	309	328	368/405	538	538/613
Y	110	123	140	159	176	195	219	258	314	368

Dimensioni non impegnative - Not binding dimensions - unverbindliche Abmessungen

3 COPPIE
 3 STAGES
 3 STUFIGE

VARVEL - RC

DIMENSIONI DI INGOMBRO
 OVERALL DIMENSIONS
 ABMESSUNGEN

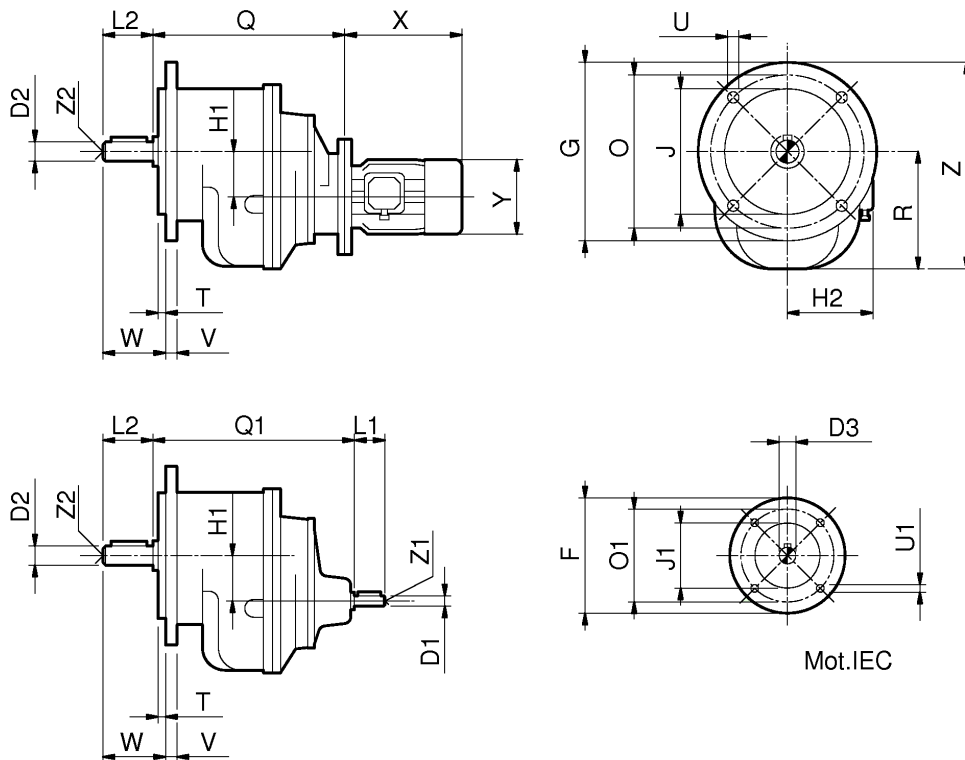
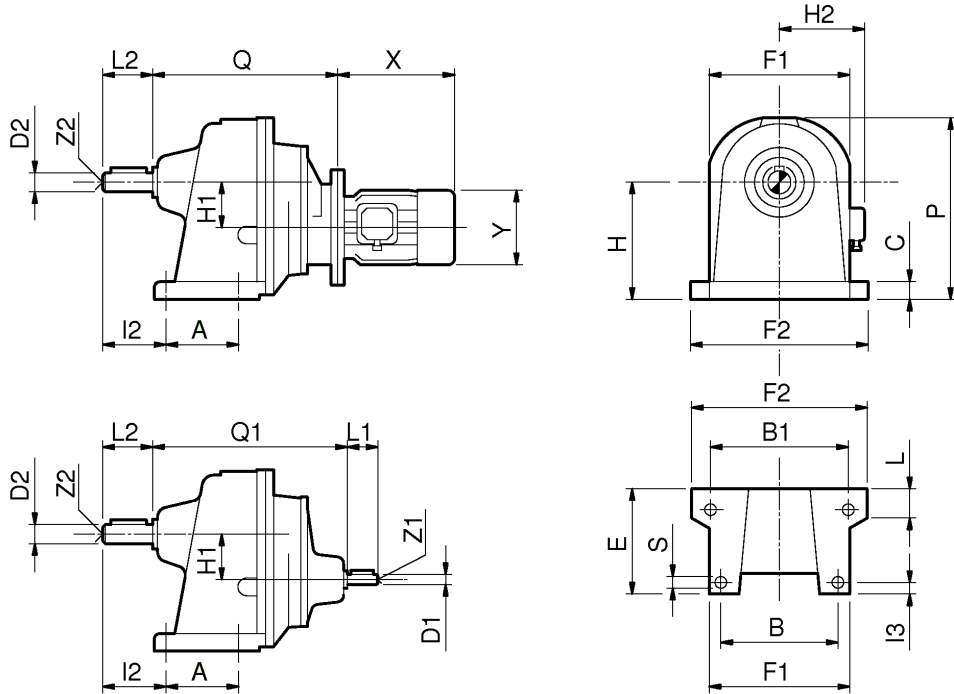

VARVEL - RC

DIMENSIONI DI INGOMBRO
OVERALL DIMENSIONS
ABMESSUNGEN

MRC	305	310	320	330	340	350	360	
A	57	58	65	85	105	140	185	
B	90	110	140	160	190	250	310	
B1	113	125	157	187	223	283	352	
C	8	9	14	17	20	28	29	
D _{1 k6}	11	11	11	14	19	24	28	
D _{2 k6}	17	20	25	32	40	50	65	
E	85	90	105	128	154	196	260	
F ₁	110	130	170	190	220	290	360	
F ₂	135	146	185	215	260	330	400	
G	140 (120/160)	160 (120/140)	200 (160)	250 (200)	300 (250)	350 (300)	450	
H	81	96	126	155	185	245	305	
H ₁	38	45	45	60	75	90	121	
I ₂	45	54	67	99	111	136	164	
I ₃	7.5	10	13	14	15	20	23	
J _{j6}	95 (80/110)	110 (80/95)	130 (110)	180 (130)	230 (180)	250 (230)	350	
L	32	32	37	47	52	62	87	
L ₁	30	30	30	30	40	50	80	
L ₂	35	40	50	80	90	110	140	
O	115 (100/130)	130 (100/115)	165 (130)	215 (165)	265 (215)	300 (265)	400	
P	130	150	195	240	285	375	468	
Q	150 (IEC56)	156 (IEC56)	176 (IEC63)	214 (IEC63)	242 (IEC71)	311 (IEC71)	394 (IEC80-90)	
	---	159 (IEC63)	186 (IEC71)	216 (IEC71)	271 (IEC80)	324 (IEC80-90)	404 (IEC100-112)	
	---	---	---	231 (IEC80)	271 (IEC90)	324 (IEC100)	434 (IEC132)	
Q ₁	156	170	186	222	272	331	427	
R	80	95	124	153	184	243	304	
S	9	9	11	13	15	17	19	
T	2	2.5	2.5	2.5	2.5	2.5	3	
U	10.5	10.5	11.5	14.5	14.5	18.5	22	
V	8	10	10	12	16	20	25	
W	39.5	46.5	53	87.5	98.5	118.5	147	
Z	151 (140/160)	175 (155/165)	224 (204)	278 (253)	334 (309)	418 (393)	529	
Z ₁	M6x15	M6x15	M8x20	M10x25	M12x30	M14x35	M14x35	
Z ₂	M4x10	M4x10	M5x12	M6x15	M8x20	M8x20	M10x25	
Mot. IEC	56 (B14)	63	71	80 (B14)	90S/L	100	112	132S/M
D ₃	9	11	14	19	24	28	28	38
F	120 (80)	140	160	200 (120)	200	250	250	300
(*) H ₂	85	95	107	122	128	140	140	180
J _{1 j6}	80 (50)	95	110	130 (80)	130	180	180	230
O ₁	100 (65)	115	130	165 (100)	165	215	215	265
U ₁	7 (M5)	9	9	11 (M6)	11	14	14	14
X	156	185	215	238	255/280	309	328	368/405
Y	110	123	140	150	176	195	219	258

Dimensioni non impegnative - Not binding dimensions - unverbindliche Abmessungen

VARVEL - RC

DIMENSIONI DI INGOMBRO
OVERALL DIMENSIONS
ABMESSUNGEN

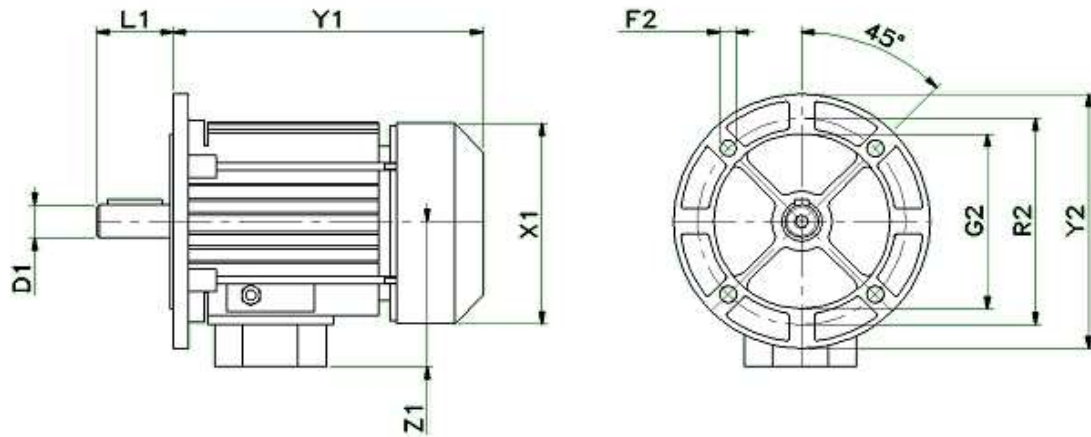

IEC	56 B14	63	71	80	90 S/L	100	112	132 S/M	160 M/L	180 M/L
D1 x L1	9 x 20	11 x 23	14 x 30	19 x 40	24 x 50	28 x 60	28 x 60	38 x 80	42 x 100	48 x 110
F2	7	9	9	11	11	14	14	14	18	18
G2	80	95	110	130	130	180	180	230	250	250
R2	100	115	130	165	165	215	215	265	300	300
X2	110	123	140	159	176	195	219	258	315	368
Y1	168	185	215	238	255/280	309	328	368/405	478/522	538/613
Y2	120	140	160	200	200	250	250	300	350	350
Z1	108	110	121	138	149	160	172	192	220	230/357
kg	2.5	4.5	6	10	13.5	21	29	43/52	68/78	160/180

Dimensioni non impegnative

- Not binding dimensions

- Durchmesser auf Anfrage

VARVEL - RC

ELENCO PARTI
PART LIST
TEILE-LISTE

1 COPPIA
1 STAGE
1 STUFIG

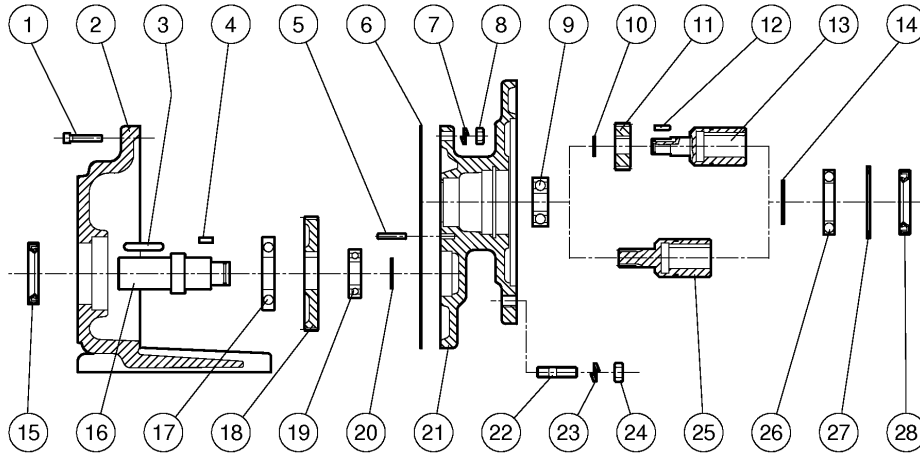

1	Vite	Screw	Schraube
2	Carcassa B3 o B5	Housing B3 or B5	Gehäuse
3	Linguetta	Key	Keil
4	Linguetta	Key	Keil
5	Spina cilindrica	Parallel pin	zylindrisch Stift
6	Guarnizione	Gasket	Dichtung
7	Rondella	Washer	Scheibe
8	Dado	Nut	Mutter
9	Cuscinetto (2Z = V1, V5)	Bearing (2Z = V1, V5)	Lager (2Z = V1, V5)
10	Anello di arresto	Seeger ring	Seegerring
11	Pignone	Pinion	Ritzel
12	Linguetta	Key	Keil
13	Manicotto	Hollow input	Eingangshohlwelle
14	Anello di arresto	Seeger ring	Seegerring
15	Anello di tenuta	Oilseal	Öldichtung
16	Albero uscita	Output shaft	Ausgangswelle
17	Cuscinetto (2Z = V3, V6)	Bearing (2Z = V3, V6)	Lager (2Z = V1, V5)
18	Ruota	Gear	Rad
19	Cuscinetto (2Z = V1, V5)	Bearing (2Z = V1, V5)	Lager (2Z = V1, V5)
20	Anello di arresto	Seeger ring	Seegerring
21	Coperchio entrata	Input cover	Eingangsdeckel
22	Vite	Screw	Schraube
23	Rondella	Washer	Scheibe
24	Dado	Nut	Mutter
25	Manicotto dentato 1:8.3	Hollow pinion 1:8.3	Hohlritzel 1:8.3
26	Cuscinetto (2Z = V1, V5)	Bearing (2Z = V1, V5)	Lager (2Z = V1, V5)
27	Anello di arresto	Seeger ring	Seegerring
28	Anello di tenuta	Oilseal	Öldichtung

VARVEL - RC

2 COPPIE
2 STAGES
2 STUFIGE

ELENCO PARTI
PART LIST
TEILE-LISTE

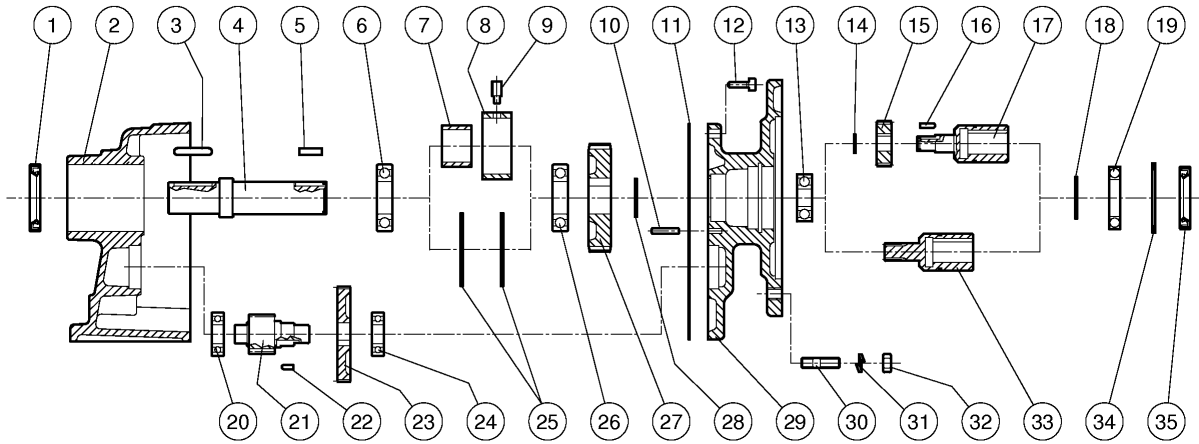

1	Anello di tenuta	Oilseal	Öldichtung
2	Carcassa B3 o B5	Housing B3 or B5	Gehäuse B3 oder B5
3	Linguetta	Key	Keile
4	Albero uscita	Output shaft	Ausgangswelle
5	Linguetta	Key	Keil
6	Cuscinetto (2Z = V3, V6)	Bearing (2Z = V3, V6)	Lager (2Z = V3, V6)
7	Distanziale - RC 40, 50, 60	Spacer - RC 40, 50, 60	Distanzring - RC 40, 50, 60
8	Distanziale - RC 40, 50, 60	Spacer - RC 40, 50, 60	Distanzring - RC 40, 50, 60
9	Vite - RC 40, 50, 60	Screw - RC 40, 50, 60	Schraube - RC 40, 50, 60
10	Spina cilindrica	Parallel pin	zylindrisch Stift
11	Guarnizione	Gasket	Dichtung
12	Vite	Screw	Schraube
13	Cuscinetto (2Z = V1, V5)	Bearing (2Z = V1, V5)	Lager (2Z = V3, V6)
14	Anello di arresto	Seeger ring	Seegerring
15	Pignone	Pinion	Ritzel
16	Linguetta	Key	Keil
17	Manicotto	Hollow input	Eingangshohlwelle
18	Anello di arresto	Seeger ring	Seegerring
19	Cuscinetto (2Z = V1, V5)	Bearing (2Z = V1, V5)	Lager (2Z = V3, V6)
20	Cuscinetto (2Z = V3, V6)	Bearing (2Z = V3, V6)	Lager (2Z = V3, V6)
21	Pignone	Pinion	Ritzel
22	Linguetta	Key	Keil
23	Ruota	Gear	Rad
24	Cuscinetto (2Z = V1, V5)	Bearing (2Z = V1, V5)	Lager (2Z = V3, V6)
25	Anello di arresto - RC 05-30	Seeger ring - RC 05-30	Seegerring
26	Cuscinetto (2Z = V3, V6)	Bearing (2Z = V3, V6)	Lager (2Z = V3, V6)
27	Ruota	Gear	Rad
28	Anello di arresto	Seeger ring	Seegerring
29	Coperchio entrata	Input cover	Eingangsdeckel
30	Vite	Screw	Schraube
31	Rondella	Washer	Scheibe
32	Dado	Nut	Mutter
33	Manicotto dentato 1:8.3	Hollow pinion 1:8.3	Hohlritzel 1:8.3
34	Anello di arresto	Seeger ring	Seegerring
35	Anello di tenuta	Oilseal	Öldichtung

VARVEL - RC

3 COPPIE
3 STAGES
3 STUFIGE

ELENCO PARTI
PART LIST
TEILE-LISTE

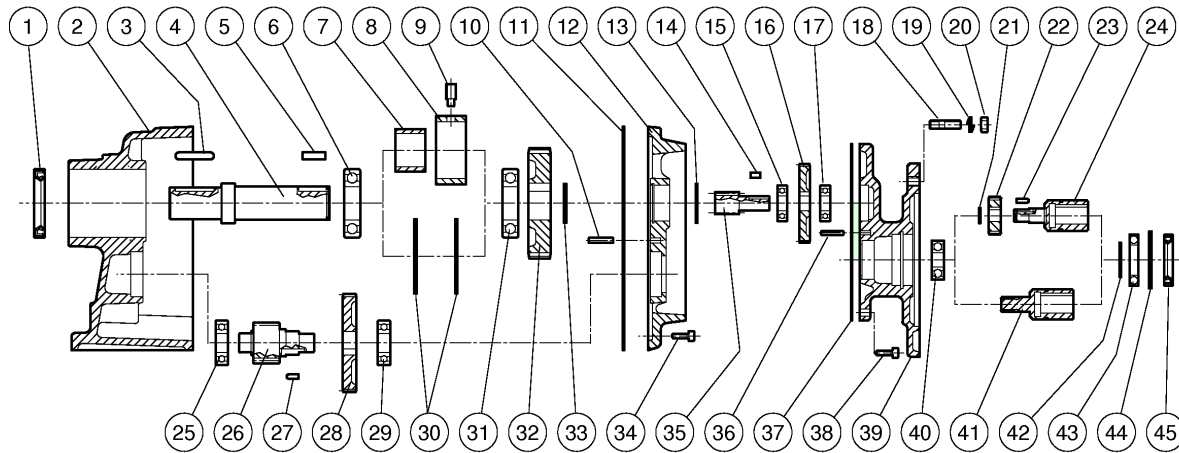

1	Anello di tenuta	Oilseal	Öldichtung
2	Carcassa B3 o B5	Housing B3 or B5	Gehäuse B3 oder B5
3	Linguetta	Key	Keil
4	Albero uscita	Output shaft	Ausgangswelle
5	Linguetta	Key	Keil
6	Cuscinetto (* = V3, V6)	Bearing (2Z = V3, V6)	Lager (2Z = V3, V6)
7	Distanziale - RC 40, 50, 60	Spacer - RC 40, 50, 60	Distanzring - RC 40, 50, 60
8	Distanziale - RC 40, 50, 60	Spacer - RC 40, 50, 60	Distanzring - RC 40, 50, 60
9	Vite - RC 40, 50, 60	Screw - RC 40, 50, 60	Schraube - RC 40, 50, 60
10	Spina cilindrica	Parallel pin	zylindrisch Stift
11	Guarnizione	Gasket	Dichtung
12	Coperchio 3a coppia	Adapter 3 rd stage	Deckel 3-stufige
13	Anello di arresto	Seeger ring	Seegerring
14	Linguetta	Key	Keil
15	Cuscinetto (* = V1, V5)	Bearing (2Z* = V1, V5)	Lager (2Z = V3, V6)
16	Ruota	Gear	Rad
17	Cuscinetto (* = V1, V5)	Bearing (2Z* = V1, V5)	Lager (2Z = V3, V6)
18	Vite	Screw	Schraube
19	Rondella	Washer	Scheibe
20	Dado	Nut	Mutter
21	Anello di arresto	Seeger ring	Seegerring
22	Pignone	Pinion	Ritzel
23	Linguetta	Key	Keile
24	Manicotto	Hollow input	Antriebshohlwelle
25	Cuscinetto (* = V3, V6)	Bearing (2Z = V3, V6)	Lager (2Z = V3, V6)
26	Pignone	Pinion	Ritzel
27	Linguetta	Key	Keil
28	Ruota	Gear	Rad
29	Cuscinetto (2Z = V3, V6)	Bearing (2Z = V3, V6)	Lager (2Z = V3, V6)
30	Anello di arresto - RC 05-30	Circlip - RC 05-30	Seegerring - RC 05-30
31	Cuscinetto (* = V3, V6)	Bearing (2Z = V3, V6)	Lager (2Z = V3, V6)
32	Ruota	Gear	Rad
33	Anello di arresto	Seeger ring	Seegerring
34	Vite	Screw	Schraube
35	Pignone	Pinion	Ritzel
36	Spina cilindrica	Parallel pin	zylindrisch Stift
37	Guarnizione	Gasket	Dichtung
38	Vite	Screw	Schraube
39	Coperchio entrata	Input cover	Eingangsdeckel
40	Cuscinetto (* = V1, V5)	Bearing (2Z = V1, V5)	Lager (2Z = V3, V6)
41	Manicotto dentato 1:8.3	Hollow pinion 1:8.3	Hohlrad 1:8.3
42	Anello di arresto	Seeger ring	Seegerring
43	Cuscinetto (* = V1, V5)	Bearing (2Z = V1, V5)	Lager (2Z = V3, V6)
44	Anello di arresto	Seeger ring	Seegerring
45	Anello di tenuta	Oilseal	Öldichtung

VARVEL - RC

Estratto delle ISTRUZIONI DI USO E MANUTENZIONE Abstract of OPERATION AND MAINTENANCE INSTRUCTIONS Auszug der BETRIEBS- UND WARTUNGSANWEISUNGEN

I riduttori e i variatori di velocità non ricadono nel campo d'applicazione della Direttiva Macchine, art.1(2) e non possono essere messi in servizio finché la macchina nella quale devono essere incorporati, sia stata dichiarata conforme all'art. 4(2), all. II(B) delle Direttive Macchine 98/37/CEE/22.6.98 e, solo per l'Italia, al DL 459/24.7.96.

Installazione

Accertarsi che il gruppo da installare abbia le caratteristiche atte a svolgere la funzione richiesta e che la posizione di montaggio sia coerente con quanto ordinato. Tali caratteristiche sono deducibili dalla targhetta di identificazione apposta sul riduttore. Effettuare la verifica della stabilità del montaggio affinché non si verifichino vibrazioni o sovraccarichi durante il funzionamento.

Funzionamento

Il riduttore può essere collegato per rotazione oraria o antioraria. Arrestare immediatamente il riduttore in caso di funzionamento difettoso o di rumorosità anomala, rimuovere il difetto o ritornare l'apparecchio alla fabbrica per una adeguata revisione. Se la parte difettosa non viene sostituita, anche altre parti possono venire danneggiate con conseguenti ulteriori danneggiamenti e più scarsa possibilità di risalire alle cause.

Manutenzione

Sebbene i gruppi siano provati con funzionamento senza carico prima della spedizione, è consigliabile non usarli a carico massimo durante le prime 20-30 ore di funzionamento affinché le parti interne possano adattarsi reciprocamente. I riduttori sono spediti già riempiti con olio sintetico a lunga durata e, se occorre sostituire o rabboccare il lubrificante, non mescolare oli a base sintetica con oli a base minerale.

Movimentazione

In caso di sollevamenti con paranco, utilizzare posizioni di aggancio sulla struttura della carcassa, golfari ove esistenti, fori dei piedi o sulle flange, evitando tutte le parti mobili.

Verniciatura

Qualora il gruppo subisca una verniciatura successiva, è necessario proteggere accuratamente gli anelli di tenuta, i piani di accoppiamento e gli alberi sporgenti.

Conservazione prolungata a magazzino

Per permanenze maggiori di 3 mesi, è consigliata la applicazione di antiossidanti sui alberi esterni e piani lavorati, e di grasso protettivo sui labbri dei paraolio.

Gestione Ambientale del prodotto

In conformità alla Certificazione Ambientale ISO14001, vengono suggerite le seguenti indicazioni per lo smaltimento del nostro prodotto:

- i componenti del gruppo che vengono rottamati debbono essere consegnati a centri di raccolta autorizzati per i materiali metallici;
- gli oli ed i lubrificanti raccolti dal gruppo devono essere smaltiti consegnandoli ai Consorzi Oli esausti;
- gli imballi a corredo dei gruppi (paletta, cartone, carta, plastica, ecc.) vanno avviati per quanto più possibile al recupero/riciclo, consegnandoli a ditte autorizzate per le singole classi di rifiuto.

Variable speed and gear boxes are not part of the field of application of the Machinery Directive, art.1(2), and they must not be put into service until the machinery into which they are to be incorporated, has been declared in conformity with the provision of art.4(2), annex II(B) of Machinery Directives 98/37/CEE/22.6.98 and for Italy only, of DL 459/24.7.96.

Installation

Check if the unit to be installed, is properly selected to perform the required function and that its mounting position complies with the order. The nameplate reports such information. Check mounting stability is adequate to run the unit without vibrations or overloads.

Running

The unit may be connected for clockwise or counter-clockwise rotation.

The unit must be stopped as soon as defective running or unexpected noise occurs, remove the faulty part or return the unit to the factory for checking.

If the faulty part is not replaced, other parts can also be affected, causing more severe damage and making the identification of initial cause more difficult.

Maintenance

Although the units are no-load run tested in the factory before despatch, it is recommended not to run them at maximum load for the first 20-30 running hours to allow the proper running in.

The gearboxes are delivered already filled with long-life synthetic oil and, in case of replacement or topping, do not mix with mineral lubricants.

Handling

When hoisting, use relevant housing locations or eyebolts if provided, or foot or flange holes. Never hoist on any moving part.

Painting

Carefully protect oilseals, coupling faces and shafts when units are re-painted.

Long-term storage

For storage periods longer than 3 months, apply antioxidants onto shafts and machined surfaces, and protective grease on oilseal lips.

Product Environmental Management

In conformity with Environmental Certification ISO 14001, we recommend the following to dispose of our products:

- scrapped components of the units to deliver to authorized centres for metal object collection;
- oils and lubricants drained from the units to deliver to Exhausted Oil Centres;
- packages (pallets, carton boxes, paper, plastic, etc.) to deliver into regeneration/recycling circuits as far as possible, by delivering separate waste classes to authorized companies.

Varvel-Getriebe und Variatoren fallen nicht unter den Geltungsbereich der Maschinenrichtlinien Art. 1(2). Sie dürfen jedoch nicht in Betrieb gesetzt werden, bevor sich nicht Maschinen, in die sie eingebaut werden, mit Art. 4(2), Anhang II(B) der Maschinenrichtlinien 98/37/CEE/22.6.98 und (nur für Italien) DL 459/24.7.96 in Übereinstimmung befinden.

Aufstellung

Vor der Aufstellung ist zu prüfen, dass die Antriebseinheit in bezug auf die Betriebsbedingungen richtig ausgewählt wurde und die Einbaulage mit der Bestellung übereinstimmt. Angaben hierüber sind auf dem Typenschild zu finden. Die Stützkonstruktion für die Getriebe ist so stabil auszuführen, dass keine Schwingungen oder Überlastungen auftreten, eventuell sind elastische Kupplungen oder Drehmomentbegrenzer zu verwenden.

Inbetriebnahme

Die Antriebseinheit kann in beiden Drehrichtungen eingesetzt werden. Die Einheit muss sofort angehalten werden, wenn ein unzulässiger Lauf oder unerwartete Geräusche auftreten. Das fehlerhafte Teil ist zu ersetzen oder die Einheit ist zur Überprüfung einzuschicken. Falls das fehlerhafte Teil nicht ersetzt wird, kann dies zu weiteren Schäden an anderen Bauteilen führen, was eine Feststellung der Ursachen sehr schwierig machen kann.

Wartung

Obwohl die Einheiten vor der Auslieferung im Leerlauf getestet wurden, ist es ratsam, sie in den ersten 20-30 Stunden nicht mit Vorlast zu betreiben, um ein einwandfreies Einlaufen der Einheiten zu gewährleisten. Die Einheiten werden entsprechend den Angaben auf dem Typenschild mit synthetischem Schmierstoff lebensdauer-geschmiert ausgeliefert. Bei einem eventuellen Ölwechsel oder Nachfüllen darf der Schmierstoff nicht mit Mineralöl vermischt werden..

Handhabung und Transport

Beim Hochheben der Einheiten sind dabei geeignete Bereiche am Gehäuse oder, falls vorgesehen, Aufhängeösen oder Fuß- bzw. Flanschbohrungen zu benutzen. Bewegliche Teile dürfen nicht zum Anheben benutzt werden.

Anstrich

Beim Erneuern oder dem zusätzlichen Aufbringen eines Anstriches sind die Dichtungen, Kupplungssitze und Wellen sorgfältig zu schützen.

Langzeitlagerung

Die Einlagerung der Einheiten muss trocken und staubfrei erfolgen. Bei einer Einlagerungszeit über 3 Monate sind bearbeitete Flächen (außer Aluminium) und Wellen mit Rostschutzmitteln zu besprühen, Dichtlippen sind mit Fett zu schützen.

Entsorgung

In Übereinstimmung mit ISO 14001 weisen wir darauf hin, im Falle Verschrottens des einzelnen Metallteile getrennt zu behandeln und Schmiermittel bei den befugten Stellen zu entsorgen. Verpackungen sollten soweit möglich wieder verwendet werden.